



**VARVEL®**

MOTION CONTROL SINCE 1955



technology made in Italy





## *Technology Made in Italy*

*Since 1955 Varvel has been making speed reducers and variators for light industry applications. Reliable partner in power transmission equipment offers also customized solutions always according to a socially responsible company values. Modularity and flexibility lead Varvel products by a unique kit form, common to all gearbox series. This feature allows distributors an easier job to set up required products in few minutes.*

---

# RS & RT

WORM GEAR BOXES



## Gearboxes Series RS & RT

### Product description

#### Multipurpose mounting

Aluminium die cast  
and Cast iron (from size 110 up)

#### Wormshafts

Z1 profile,  
Hardened and ground.  
Alloy steel.

#### Wormwheels

Bronze alloy cast  
onto a cast iron hub.

#### Bearings

Ball or roller types.  
Tapered roller bearings  
For heavy duty operation.



**Input**  
IEC and NEMA  
motor adapters and  
Universal Elastic Coupling

**Oil seals**  
Nitrile Butadiene Rubber - NBR  
as standard;  
Viton and Silicone on request.

**Output**  
Hollow bore as standard;  
Single or Double solid shaft  
on request.

#### Modular attachments

Helical one stage gearbox,  
Output Flange, Torque Arm and Torque Limiter.

#### Single worm gear boxes RS and RT

The worm gearboxes, RS and RT series, specifically designed for universal mounting, are manufactured with die cast housings and covers in aluminium up to the size 85 and cast iron from the size 110.

Torques listed in selection tables are output torque values for the specific size, and motor powers are always referred to 1440 rpm.

Input Viton oil seals, fitted on request, allow trouble-free operation with 2-pole standard ac motors or 3000 rpm dc motors and Silicone oil seals for low temperatures.

Gearboxes are delivered filled with synthetic long-life oil (without plugs), in quantities as recommended on page 17, and valid for all mounting positions.

Selection table data are intended for service factor SF1.0 i.e. 8-10 running hours per day, uniform load, less than 6 start/ stops per hour, and room temperature ranging from 15 to 35 °C .

#### Helical worm gear boxes RA and TA

The gearboxes, RA and TA series, made up of an independent single stage helical gearbox FXA fitted to a standard FRS or FTR gearbox, allow greater output torques and higher efficiency than the FRS and FRT gearbox with equivalent ratios.

## Gearboxes Series RS & RT

### Product description

#### Two stage worm gear boxes RS/RS and RT/RT

The gearboxes, RS/RS and RT/RT series, are made up of two gearboxes RS or RT and offer a full selection of high reduction ratios to obtain lower output speeds.

#### Output shafts AS and AD

All gearboxes are manufactured with hollow output shaft as standard. Optionally, a single AS or double AD solid output shaft - made of steel C43 - can be supplied.

An ASC safety shield for the opposite side of a single output shaft AS, is available on demand.

#### Torque arms BR/BRV and BT/BTV

Standard gearboxes are normally supplied with covers on each side for attaching a torque arm when gearboxes have to operate as shaft mounted units.

The torque arm, standard or with Vulkollan vibration-damping, is made of extra thick plate and white galvanized

#### Torque limiters TLI and TLE

The torque limiter and safeguard device - TLI built-in inside the gearbox and TLE fitted outside - allows easy torque adjustments, full gearbox safeguard against unexpected overload conditions, simple hand release, and manual operation in case of power supply failure.

The factory preset slipping torque can be adjusted from the maximum preset torque down to zero. Shaft rotation restarts automatically as soon as torque value is lower than the preset value.

Oil quantity of torque limiter TLI are listed at page 42 and 50.

#### Travel limiters SL

The SL travel limiter device stops - by means of built-in limit switches - the gear-box after a given operation time.

Standard thread allows approx. 40 turns of the output shaft. Limit switch travel is adjustable and operation time varies upon the used reduction ratio from min. 12 to max. 170 seconds .

#### Directive ATEX

The gearboxes VARVEL-ATEX, delivered on demand, are designed and manufactured according to Directive 94/9/CE "ATEX" and therefore, they are qualified for installation in potentially explosive atmospheres:

- Zones of Group II,
- Category 2 (or 3),
- Explosion hazard with gas presence (Zone 1 or 2),
- Explosion hazard with combustible dust presence (Zone 21 or 22).

The units VARVEL-ATEX are identified by the additional marking :

 II 2 GD ck IP66 T<sub>max</sub>=135 °C

## Gearboxes Series RS & RT

### Product description



	GENERAL SPECIFICATIONS
Range	Sizes: 9 RS + 7 RT 55 reduction ratios 3020 Nm max. output torque
Sizing	According to BS721. 15,000 hrs average lifetime with service factor SF1
Housing, Covers	Pressure die cast aluminium AlSi12Cu2Fe till size 85 and cast iron from size 110.
Coupling G input	Pressure die cast aluminium AlSi12Cu2Fe for sizes 3, 5, 6 and alloyed steel from size 8
Toothed parts	Worms of steel 20MnCr5 CH and tooth profile ZI and ZK ground. Wheels of bronze CuSn12 on Cast Iron hub.
Shafts & Keys	Steel C43 Shafts h6 - Bores E8 Keys according to DIN6885 B1
Bearings	Ball- or roller-types according to sizes and technical requirements
Oil seals	Type NBR - Nitrile Butadiene Rubber with additional anti-dust lip according to DIN 3760
Lubricant	Synthetic long-life oil Grade ISO VG 320

## Gearboxes Series RS & RT

### Symbols

$F_r$ [N]	Application radial load	
$F_{r1}$ [N]	Catalogue radial load (input)	
$F_{r2}$ [N]	Catalogue radial load (output)	
FS	Service factor	$FS = \frac{M_2}{M_{(app)}}$
$i$	Reduction ratio (real)	
Lub [l]	Lubricant (litres)	
$M_2$ [Nm]	Gearbox output torque	
$M_{(app)}$ [Nm]	Application torque	
$n_1$ [ $\text{min}^{-1}$ ]	Input speed	
$n_2$ [ $\text{min}^{-1}$ ]	Output speed	
$P_1$ [kW]	Motor power	$P_1 = \frac{M_2 * n_2}{9550 * \eta}$
$P_{(kg)}$ [kg]	Weight	
$\eta$	Efficiency	



## Gearboxes Series RS & RT

Modular system

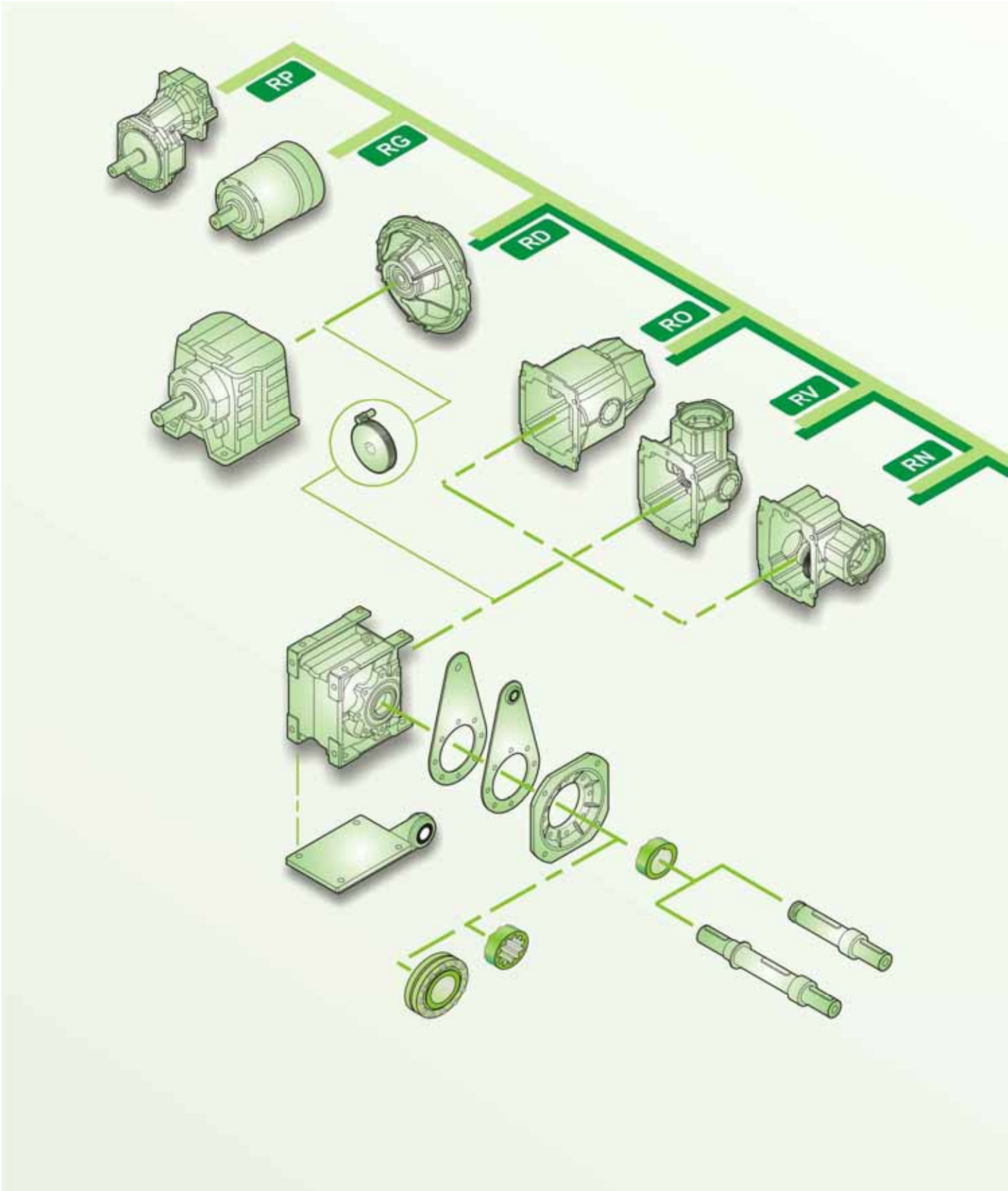



## Gearboxes Series RS & RT

Modular system

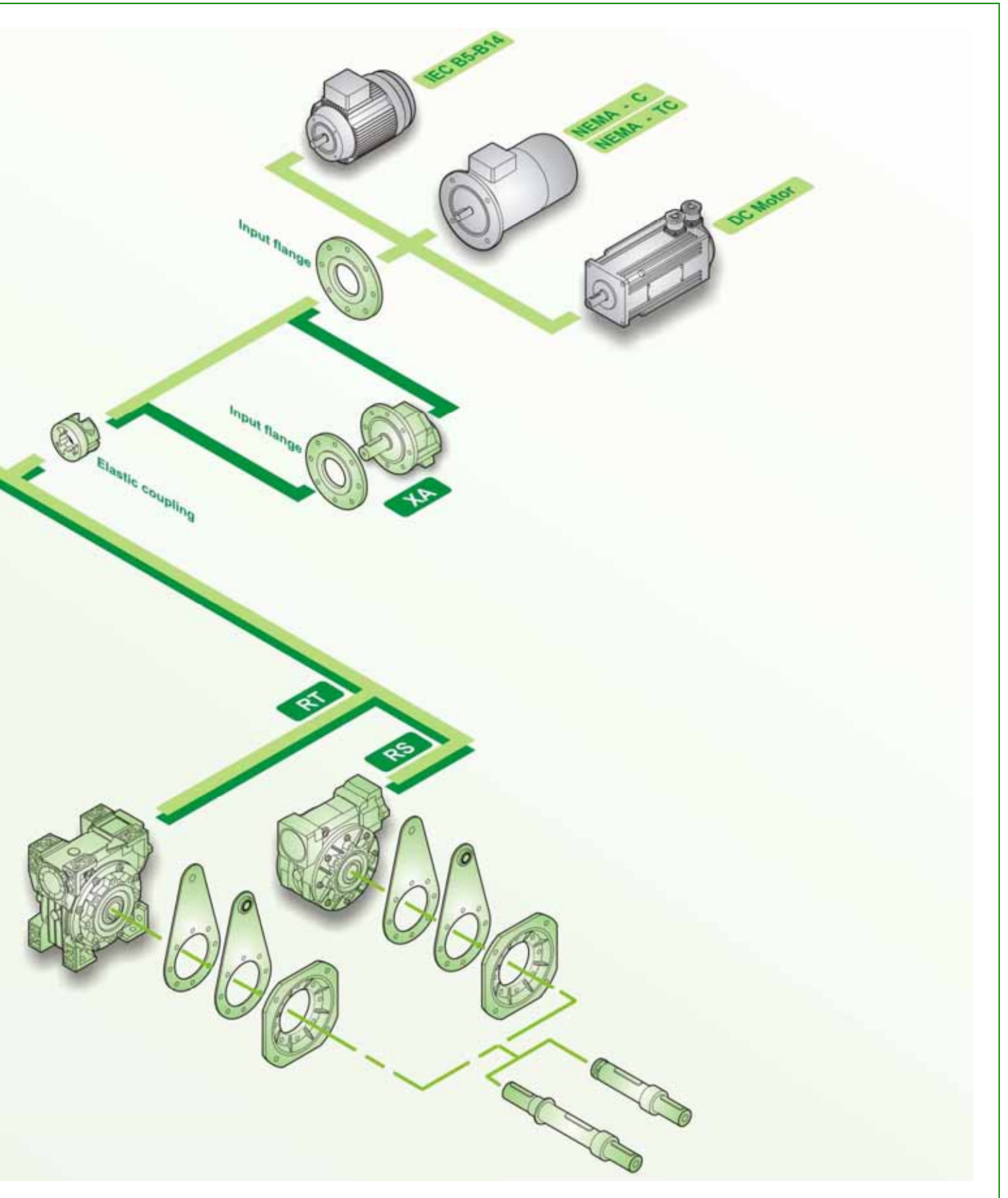

## Gearboxes Series RS & RT

### Elastic coupling "G" description

#### Reducer half-coupling

- Material: steel 20MnCr5
- Input shaft built-in
- Two bearing set
- Unchanged casing dimensions

#### Spider

- External tooth connection
- Material: Thermoplastic Elastomer
  - Elastollan<sup>®</sup> TPU - Polyurethane
  - Hytrel<sup>®</sup> TPE - Polyester
- Hardness
  - TPU 98 Shore A
  - TPE 72 Shore D
- Temperature
  - TPU -20/+75°C (-4 / +167°F)
  - TPE -30/+100°C (-22 / +212°F)

#### Motor half-coupling

- Material:
  - Aluminium die cast (G3, G5, G6)
  - Steel 36SMnPb14 (GS8)
  - Steel C43 on demand (GS3, GS5, GS6)
- Dynamic balancing
- Fitting:
  - Clamp (G3, G5, G6)
  - Key (GS3, GS5, GS6, GS8)
- Bores:
  - IEC 72 / N42948
  - NEMA C y TC

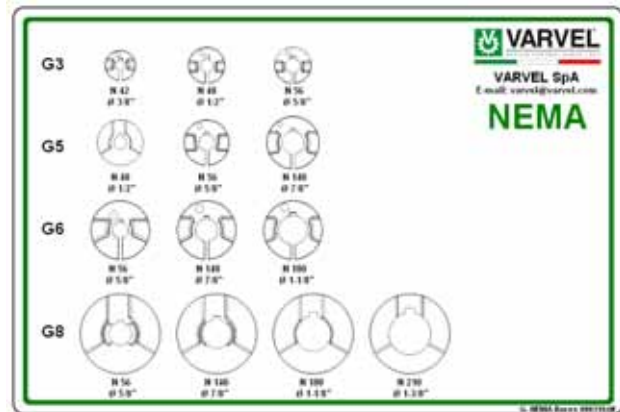
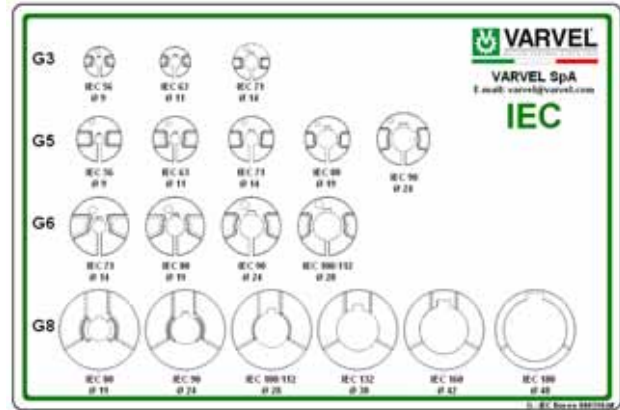

#### Advantages:

- One gearbox only for each reduction ratio
- Greater flexibility
- Increased stock rotation
- Fretting corrosion elimination between key and keyway
- Zero backlash in gearbox/motor connection
- Allowed angular misalignment 1° max
- Torsional rigidity
- High vibration damping

#### Input flanges:

- Material:
  - Aluminium up to IEC112 and NEMA TC180
  - Cast iron from IEC 132 and NEMA TC200

## Gearboxes Series RS & RT

### Elastic coupling "G" selection

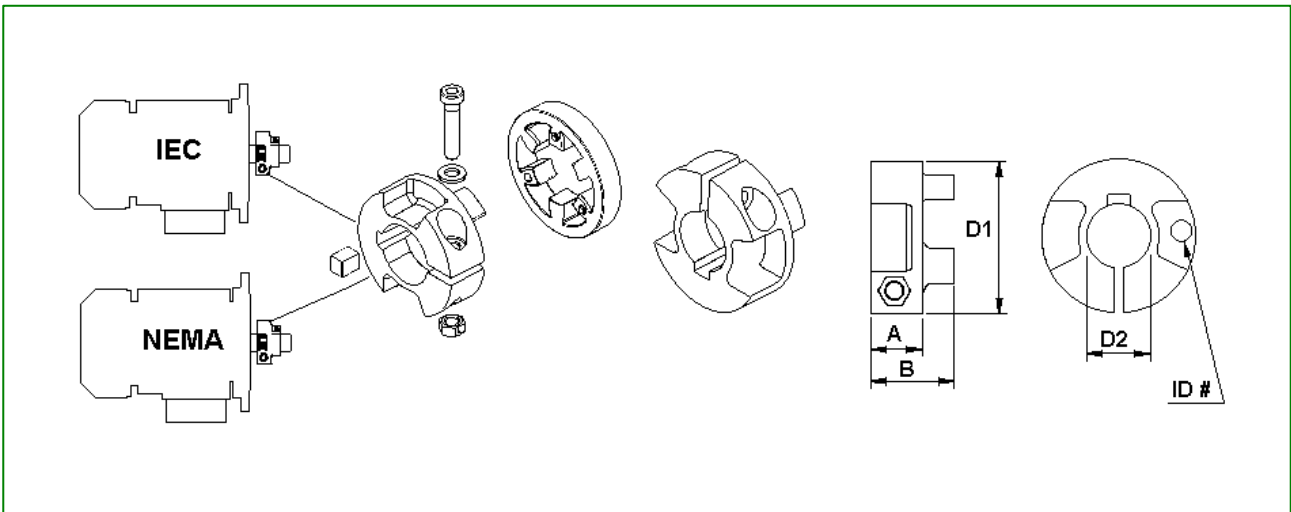

Type	IEC NEMA	Kit Part No.	RS - RT	Mt [Nm]	Mt1 [Nm]	Mt2 [Nm]	A [mm]	B [mm]	D1 [mm]	D2 [mm/inch]	ID#
G3	IEC	KG3.009	28-40	4.5 - 6	15	8 - 10	11	19	30	9	309
		KG3.011	28-40	4.5 - 6	15	8 - 10			30	11	311
		KG3.014	40	7 - 8.5	28	18 - 22			36	14	314
	NEMA	KG3.N42	28-40	4.5 - 6	16	8 - 10			30	3/8"	3N42
		KG3.N48	28-40	4.5 - 6	18	10 - 12			36	1/2"	3N48
		KG3.N56	40	7 - 8.5	30	20 - 24			36	5/8"	3N56
G5	IEC	KG5.011	50-60	8.9 - 10	15	8 - 10	14.5	23	45	11	311
		KG5.014	50-60		30	12 - 17			45	14	314
		KG5.019	50-60		40	20 - 25			45	19	319
		KG5.024	60		70	30 - 40			52	24	324
	NEMA	KG5.N56	50-60		45	30 - 35			45	5/8"	5N56
		KG5.N140	60		60	40 - 45			52	7/8"	5N140
G6	IEC	KG6.014	70	15.3 - 18	60	30 - 40	19.5	31.5	58	14	614
		KG6.019	70-85-110		90	50 - 65				19	619
		KG6.024	70-85-110		130	85 - 100				24	624
		KG6.028	70-85-110		180	100 - 120				28	628
	NEMA	KG6.N56	70-85-110		50	---				5/8"	6N56
		KG6.N140	70-85-110		85	---				7/8"	6N140
		KG6.N180	70-85-110	200	---	1-1/8"	6N180				

Mt - Screw locking torque  
 Mt1 - Transmissible torque with key  
 Mt2 - Transmissible torque without key

## Gearboxes Series RS & RT

### IEC - Flanges and Elastic coupling selection

RS - RT	Flange Type	IEC	Kit Part No.		Elastic coupling	
			Flange B5	Flange B14	Type	Kit Part No.
RS-RT 28	FM 28	IEC56 IEC63	K530.206.120 K530.206.140	K530.206.080 K530.206.090	G3 ø9 G3 ø11	KG3.009 KG3.011
RS-RT 40	FM 40	IEC56 IEC63 IEC71	K531.206.120 K531.206.140 K531.206.160	K531.206.080 K531.206.090 K531.206.105	G3 ø9 G3 ø11 G3 ø14	KG3.009 KG3.011 KG3.014
RS-RT 50	FM 50	IEC63 IEC71 IEC80	K532.206.140 K532.206.160 K532.206.200	K532.206.090 K532.206.105 K532.206.120	G5 ø11 G5 ø14 G5 ø19	KG5.011 KG5.014 KG5.019
RS-RT 60	FM 60	IEC71 IEC80 IEC90	K539.206.160 K539.206.200 K539.206.200	K539.206.105 K539.206.120 K539.206.140	G5 ø14 G5 ø19 G5 ø24	KG5.014 KG5.019 KG5.024
RS-RT 70	FM 70	IEC71 IEC80 IEC90 IEC100	K533.206.160 K533.206.200 K533.206.200 K533.206.250	K533.206.105 K533.206.120 K533.206.140 K533.206.160	G6 ø14 G6 ø19 G6 ø24 G6 ø28	KG6.014 KG6.019 KG6.024 KG6.028
RS-RT 85	FM 85	IEC80 IEC90 IEC100/112	K534.206.200 K534.206.200 K534.206.250	K534.206.120 K534.206.140 K534.206.160	G6 ø19 G6 ø24 G6 ø28	KG6.019 KG6.024 KG6.028
RS-RT 110	FM 110	IEC90 IEC100/112 IEC132	K535.206.200 K535.206.250 K535.206.300	--- K535.206.160 K535.206.200	G6 ø24 G6 ø28 # ø38	KG6.024 KG6.028 ---
RS 130	FM 130	IEC100/112 IEC 132	K536.206.250 K537.206.300	--- K536.206.200	# ø28 # ø38	--- ---
RS 150	FM 150	IEC100/112 IEC 132 IEC 160	K536.206.250 K537.206.300 K537.206.350	K536.206.200 K536.206.250 ---	# ø28 # ø38 # ø42	--- --- ---
XA 63	FM 40	IEC56 IEC63	K531.206.120 K531.206.140	K531.206.080 K531.206.090	# ø9 # ø11	--- ---
XA 71	FM 50	IEC71	K532.206.160	K532.206.105	# ø14	---
XA 80	FM 70	IEC80 IEC90	K533.206.200 K533.206.200	K533.206.120 K533.206.140	# ø19 # ø24	--- ---
XA 100	FM 85	IEC80 IEC90 IEC100/112	K534.206.200 K534.206.200 K534.206.250	K534.206.120 K534.206.140 K534.206.160	G6 ø19 G6 ø24 G6 ø28	KG6.019 KG6.024 KG6.028

# - Key/Keyway motor fitting

## Gearboxes Series RS & RT

### Flanges and Elastic coupling selection - NEMA

RS - RT	Flange Type	NEMA	Kit Part No.	Elastic coupling	
				Type	Kit Part No.
RS-RT 28	FM 28	42 C 48 C	K530.207.N048 K530.207.N048	G3 ø 3/8" G3 ø 1/2"	KG3.N042 KG3.N048
RS-RT 40	FM 40	42 C 48 C 56 C	K531.207.N048 K531.207.N056 K531.207.N056	G5 ø 3/8 G5 ø 1/2 G5 ø 5/8	KG3.N048 KG3.N056 KG3.N140
RS-RT 50	FM 50	56 C	K532.227.N056	G5 ø 5/8	KG5.N056
RS-RT 60	FM 60	56 C 140 TC	K539.207.N056 K539.207.N056	G6 ø 5/8 G6 ø 7/8	KG6.N056 KG6.N140
RS-RT 70	FM 70	56 C 140 TC 180 TC	K533.227.N056 K533.227.N056 K533.227.N180	G6 ø 5/8" G6 ø 7/8" G6 ø 1-1/8"	KG6.N056 KG6.N140 KG6.N180
RS-RT 85	FM 85	56 C 140 TC 180 TC	K534.207.N056 K534.207.N056 K534.207.N180	G6 ø 5/8 G6 ø 7/8 G6 ø 1-1/8	KG6.N056 KG6.N140 KG6.N180
RS-RT 110	FM 110	56 C 140 TC 180 TC	K535.227.N056 K535.227.N056 K535.227.N180	G6 ø 5/8" G6 ø 7/8" G6 ø 1-1/8"	KG6.N056 KG6.N140 KG6.N180
RS 130	FM 130	56 C 140 TC 180 TC	K536.227.N056 K536.227.N056 K536.227.N180	# ø 5/8" # ø 7/8" # ø 1-1/8"	--- --- ---
RS 150	FM 130	56 C 140 TC 180 TC 210 TC	K537.227.N056 K537.227.N056 K537.227.N180 K537.227.N180	# ø 5/8" # ø 7/8" # ø 1-1/8" # ø 1-1/8"	--- --- --- ---
XA 63	FM 40	* IEC56 * IEC63	K531.206.120 K531.206.140	# ø9 mm # ø11 mm	--- ---
XA 71	FM 50	* IEC71	K532.206.160	# ø14 mm	---
XA 80	FM 70	* IEC80 * IEC90	K533.206.200 K533.206.200	# ø19 mm # ø24 mm	--- ---
XA 100	FM 85	56 C 140 TC 180 TC	K334.227.N056 K334.227.N056 K334.227.N180	G6 ø 5/8" G6 ø 7/8" G6 ø 1-1/8"	KG6.N056 KG6.N140 KG6.N180

# - Key/keyway motor fitting  
\* - IEC input only

# Gearboxes Series RS & RT

## Designation

### GEARBOX DESIGNATION

F	SR	[../]	40	B3	28	IEC71	B14	(OPS, OPP)
								OPS = Standard options pages 42-50
								B5, B14 = Electric motor form
								Electric motor frame
								Reduction ratio
								Mounting form
								Gearbox size
								- RS (28, 40, 50, 60, 70, 85, 110, 130, 150)
								- RT (28, 40, 50, 60, 70, 85, 110)
								Helical stage size RA (63/, 71/, 80/, 100/)
								Two stage wormbox: 1st gearbox size RS - RT (28/, 40/, 50/, 60/, 70/)
								Gearbox type
								M = Geared motor
								F = IEC input flange
								S = Without IEC input flange
								... = None - Free input shaft

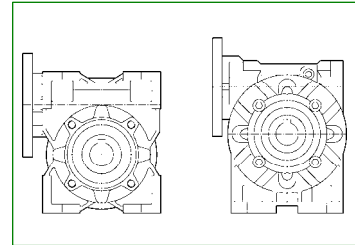

### MOTOR DESIGNATION

MT	0,37 kW	71b4	B14	230/400/50	IP55	F	X1	
								Terminal box position
								Cl. F (std) = Insulation class
								IP55 (std) = Protection class
								Voltage / Frequency
								B5 o B14 = Mounting
								IEC motor frame and number of poles
								Motor power
								MT = Three-phase motor
								MM = Single-phase motor
								MA = Brake motor

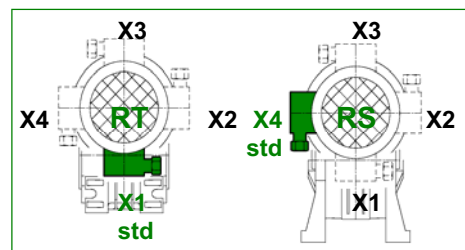

### OPTIONS OPP

Standard fitting side, unless otherwise requested, is the gearbox right side when seen from the input side.

ACØ - Not standard hollow shaft ø... mm

CS - Not standard output bearings

FL/F - Additional output flange FL/F

GRM - Reduced end play

LNS - Not standard lubrication

VB - NDE worm shaft extension

## Gearboxes Series RS & RT

Electronic catalogue



Modularity and flexibility have been leading the design of Varvel products since 2000. The gearbox-kit concept was carried out allowing anyone to assemble the unit in a few minutes with standard tooling.

This feature provides the highest flexibility to Varvel's distributors and resellers who - thanks to a limited kit selection - are able to immediately configure the required product.

VARSIZE® selection programme, available from our site

[www.varvel.com](http://www.varvel.com)

allows a friendly sizing of Varvel product range.

### 2D/3D Drawings

A guided selection allows 2D/3D models to be downloaded for the most popular CAD systems.

### Guided selection

This service returns a list of applicable product configurations upon a given sequence of application parameters (power, output torque, rpm, service factor etc.); a PDF data sheet featuring performance data and dimensional drawings is generated for each configuration, as well as the 3D model and 2D drawings .





# Gearboxes Series RS & RT

**RS**

## Standard mounting positions

### RS , RA , RS/RS

Output

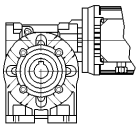
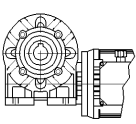
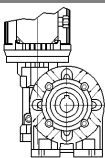
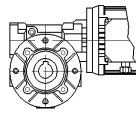
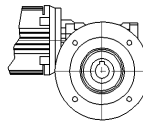
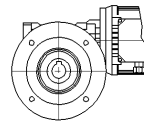
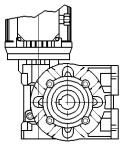
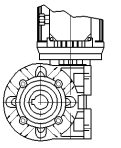
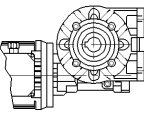
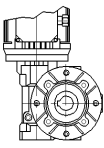
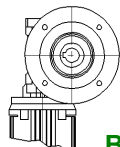
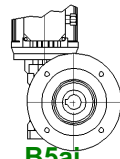
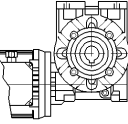
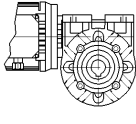
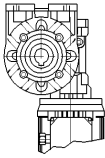
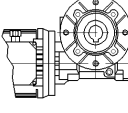
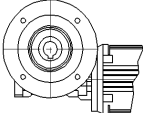
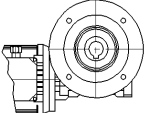
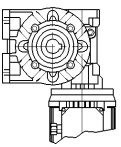
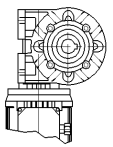
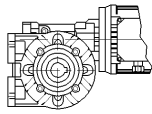
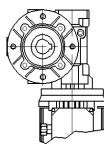
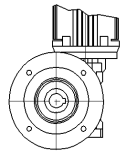
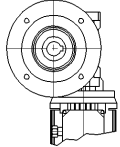
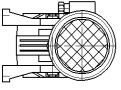
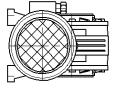
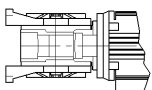
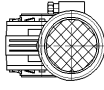
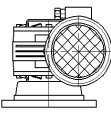
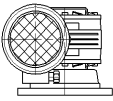
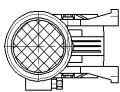
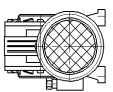
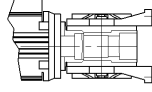
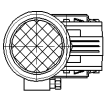
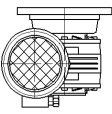
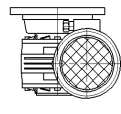
S - SA	I - IA	D - DA	PC - PC	FL - FA - FB - PA - PB	
 <b>B3 (std)</b>	 <b>B3 (std)</b>	 <b>B3 (std)</b>	 <b>B5 (std)</b>	 <b>B5 (std)</b>	 <b>B5i</b>
 <b>V5</b>	 <b>V5</b>	 <b>V5</b>	 <b>B5</b>	 <b>B5a</b>	 <b>B5ai</b>
 <b>B8</b>	 <b>B8</b>	 <b>B8</b>	 <b>B5</b>	 <b>B5b</b>	 <b>B5bi</b>
 <b>V6</b>	 <b>V6</b>	 <b>V6</b>	 <b>B5</b>	 <b>B5c</b>	 <b>B5ci</b>
 <b>B6</b>	 <b>B6</b>	 <b>B6</b>	 <b>V1</b>	 <b>V1</b>	 <b>V1i</b>
 <b>B7</b>	 <b>B7</b>	 <b>B7</b>	 <b>V3</b>	 <b>V3</b>	 <b>V3i</b>

### RA

Input

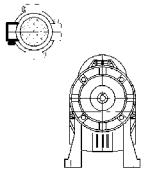
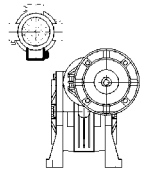
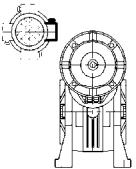
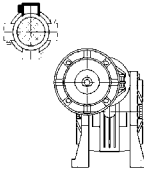
10 (std)	11	12	13		
					

# RS

# Gearboxes Series RS & RT

## Standard mounting positions

### RS / RS

Output

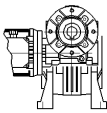
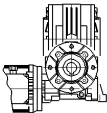
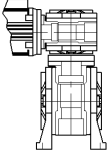
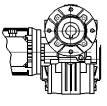
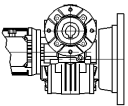
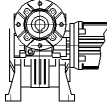
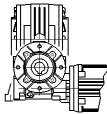
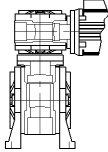
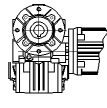
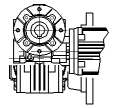
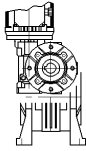
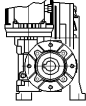
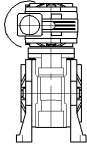
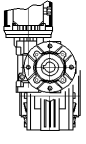
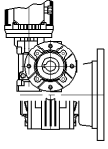
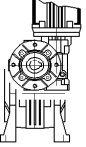
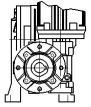
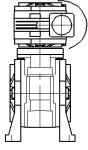
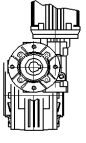
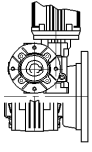
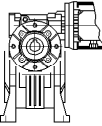
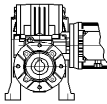
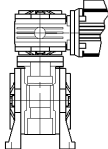
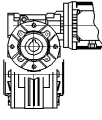
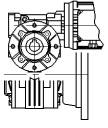
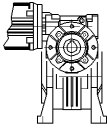
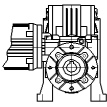
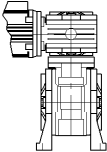
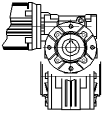
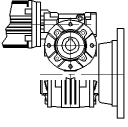
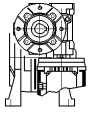
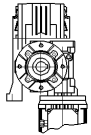
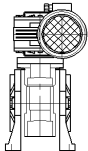
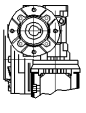
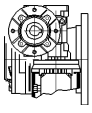
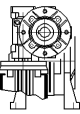
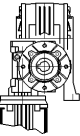
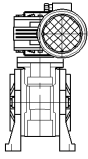
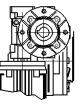
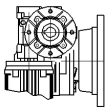
	S - SA	I - IA	D - DA	PC - PA - PB	FL - FA - FB
11					
12					
13					
14					
15					
16					
17					
18					

# Gearboxes Series RS & RT

**RT**

## Standard mounting positions

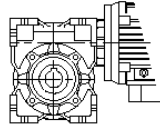
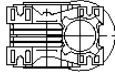
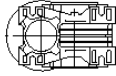
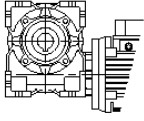
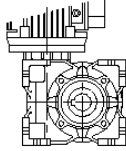
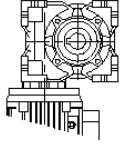
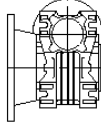
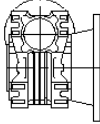
<b>RT</b> <b>TA</b> <b>RT/RT</b> Output	 <p><b>B3 (std)</b></p>	 <p><b>B6</b></p>	 <p><b>B7</b></p>	 <p><b>B8</b></p>
	 <p><b>V5</b></p>	 <p><b>V6</b></p>	 <p><b>F (std)</b></p>	 <p><b>Fi</b></p>

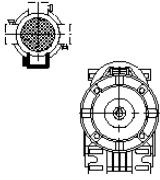
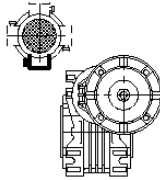
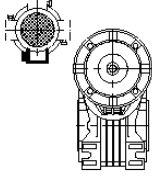
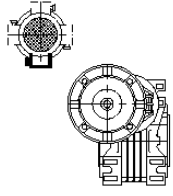
<b>TA</b> Input	 <p><b>10 (std)</b></p>	 <p><b>11</b></p>	 <p><b>12</b></p>	 <p><b>13</b></p>
--------------------	--	--	---	--

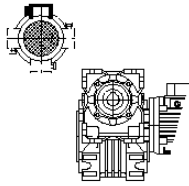
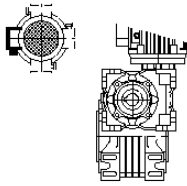
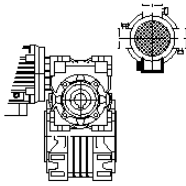
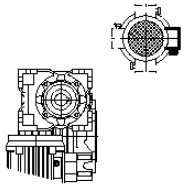
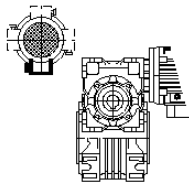
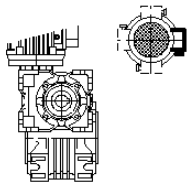
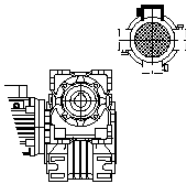
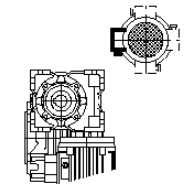
<b>RT/RT</b> Input	 <p><b>20 (std)</b></p>	 <p><b>21</b></p>	 <p><b>22</b></p>	 <p><b>23</b></p>
	 <p><b>24</b></p>	 <p><b>25</b></p>	 <p><b>26</b></p>	 <p><b>27</b></p>

## Gearboxes Series RS & RT

### Service factors - Weights - Lubricants

### SERVICE FACTORS

$$FS = F_1 \times F_2$$

Load $F_1$	uniform	variable	shock	Starts/stops $F_2$	Starts/ stops / hour
3 - 4 h	0.8	1.0	1.5	6	1.0
8 - 10 h	1.0	1.2	1.8	60	1.2
10 - 24 h	1.4	1.6	2.0	120	1.4

### WEIGHTS AND LUBRICANTS

RS - RT	kg	l	RA - RT	kg	$l_1 / l_2$	RS / RS RT / RT	kg	$l_1 / l_2$
28	1.1	0.03	63 / 40	4.0	0.04/0.08	28 / 28	2.5	0.03/0.03
40	2.5	0.08	63 / 50	5.3	0.04/0.13	28 / 40	3.9	0.03/0.08
50	3.8	0.13	63 / 60	8.0	0.04/0.20	28 / 50	5.2	0.03/0.13
60	6.5	0.20	71 / 50	6.6	0.06/0.13	28 / 60	7.9	0.03/0.20
70	9.0	0.35	71 / 60	9.3	0.06/0.20	40 / 70	12.0	0.08/0.35
85	13.5	0.60	71 / 70	11.8	0.06/0.35	40 / 85	16.5	0.08/0.60
110	39.0	1.50	71 / 85	16.3	0.06/0.60	50 / 110	45.0	0.13/1.50
*130	50.0	2.75	80 / 60	10.5	0.10/0.20	*60/130	57.0	0.25/2.75
*150	80.0	4.40	80 / 70	13.0	0.10/0.35	*70/150	90.0	0.35/4.40
			80 / 85	17.5	0.10/0.60			
			80 / 110	43.0	0.10/1.50			
			100/110	46.0	0.20/1.50			
			*100/130	64.0	0.20/2.75			
			*100/150	94.0	0.20/4.40			

\* RS only

XA	kg	l
63	1.5	0.04
71	2.2	0.06
80	3.0	0.10
100	7.0	0.20

## Gearboxes Series RS & RT

### Input loads

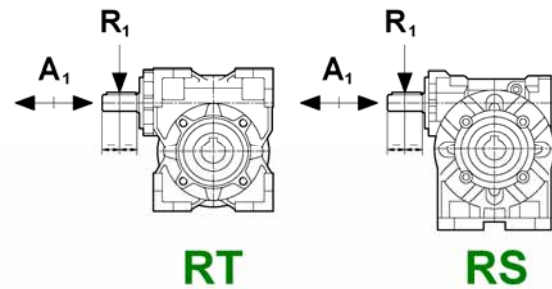

Input radial loads  $R_1$  [daN]

$$A_1 = 0,2 \times R_1$$

min <sup>-1</sup>	2800	1400	900	700	500	300
RS-RT 28	5	7	8	9	10	12
RS-RT 40	11	15	16	17	18	20
RS-RT 50	15	20	22	25	28	30
RS-RT 60	23	30	33	35	37	40
RS-RT 70	26	35	40	44	47	50
RS-RT 85	34	45	52	58	62	70
RS-RT 110	57	75	80	85	92	100
RS130	70	100	105	110	115	120
RS150	90	120	125	130	140	150

## Gearboxes Series RS & RT

### Output loads

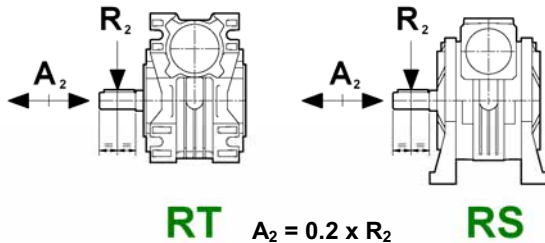

### Output radial loads $R_2$ [daN] with standard bearings

min <sup>-1</sup>	280	200	140	93	70	50	35	29	25	20	18	14	Brg No.
RS-RT 28	---	45	50	55	60	62	70	75	80	90	95	100	16005
RS-RT 40	100	100	110	120	135	150	160	170	180	190	200	230	16006
RS-RT 50	145	125	145	170	190	200	230	240	260	280	290	320	16008
RS-RT 60	225	240	250	290	330	360	390	430	320	500	420	560	①
RS-RT 70	260	270	290	360	390	420	450	520	550	590	630	670	②
RS-RT 85	330	330	370	440	470	540	550	630	660	710	750	830	③
RS-RT 110	---	390	415	520	540	590	570	750	780	800	880	980	④
RS 130	---	500	565	615	650	660	780	880	950	970	1050	1150	6015
RS 150	---	650	770	830	880	900	1100	1200	1250	1300	1400	1500	6216

① - RS: 6008 / RT: 6208

③ - RS: 6010 / RT: 6210

② - RS: 6009 / RT: 6209

④ - RS: 6012 / RT: 6212

### Output radial loads $R_2$ [daN] with heavy duty bearings

min <sup>-1</sup>	280	200	140	93	70	50	35	29	25	20	18	14	Brg No.
RS-RT 28	---	65	75	82	90	93	105	112	120	130	130	130	6005
RS-RT 40	140	150	155	165	190	210	225	240	250	260	260	260	32006
RS-RT 50	200	175	200	240	260	300	340	360	390	420	420	420	32008
RS-RT 60	290	300	320	370	420	480	510	570	610	660	660	660	30208
RS-RT 70	335	330	370	450	516	560	610	690	730	790	790	790	⑤
RS-RT 85	410	420	460	550	630	720	730	840	870	940	940	940	⑥
RS-RT 110	---	500	540	670	750	800	930	1050	1110	1110	1110	1110	⑦
RS 130	---	700	790	860	970	990	1170	1290	1420	1450	1450	1450	32015
RS 150	---	900	1080	1160	1320	1350	1650	1800	1870	1950	1950	1950	30216

⑤ - RS: 32009 / RT: 30209

⑥ - RS: 32010 / RT: 30210

⑦ - RS: 32012 / RT: 30212

# Gearboxes Series RS & RT

# FRS - FRT

**Motor frames**

FRS FRT	min <sup>-1</sup> IEC	i = 5	i7	10	15	20	28	40	49	56	70	80	100
		280	200	140	93	70	50	35	29	25	20	18	14
28	56	---	⊙	⊙	⊙	⊙	⊙	⊙	⊙	⊙	⊙	⊙	⊙
	63	---	⊙	⊙	⊙	⊙	⊙	⊙	⊙	⊙	⊙	⊙	⊙
40	56	⊙	⊙	⊙	⊙	⊙	⊙	⊙	⊙	⊙	⊙	⊙	⊙
	63	⊙	⊙	⊙	⊙	⊙	⊙	⊙	⊙	⊙	⊙	⊙	⊙
	71	⊙	⊙	⊙	⊙	⊙	⊙	⊙	⊙	⊙	⊙	⊙	⊙
50	63	⊙	⊙	⊙	⊙	⊙	⊙	⊙	⊙	⊙	⊙	⊙	⊙
	71	⊙	⊙	⊙	⊙	⊙	⊙	⊙	⊙	⊙	⊙	⊙	⊙
	80	⊙	⊙	⊙	⊙	⊙	⊙	⊙	⊙	⊙	⊙	⊙	⊙
60	71	⊙	⊙	⊙	⊙	⊙	⊙	⊙	⊙	⊙	⊙	⊙	⊙
	80	⊙	⊙	⊙	⊙	⊙	⊙	⊙	⊙	⊙	⊙	⊙	⊙
	90	⊙	⊙	⊙	⊙	⊙	⊙	⊙	⊙	⊙	⊙	⊙	⊙
70	71	⊙	⊙	⊙	⊙	⊙	⊙	⊙	⊙	⊙	⊙	⊙	⊙
	80	⊙	⊙	⊙	⊙	⊙	⊙	⊙	⊙	⊙	⊙	⊙	⊙
	90	⊙	⊙	⊙	⊙	⊙	⊙	⊙	⊙	⊙	⊙	⊙	⊙
	100	⊙	⊙	⊙	⊙	⊙	⊙	⊙	⊙	⊙	⊙	⊙	⊙
85	80	⊙	⊙	⊙	⊙	⊙	⊙	⊙	⊙	⊙	⊙	⊙	⊙
	90	⊙	⊙	⊙	⊙	⊙	⊙	⊙	⊙	⊙	⊙	⊙	⊙
	100/112	⊙	⊙	⊙	⊙	⊙	⊙	⊙	⊙	⊙	⊙	⊙	⊙
110	90	---	⊙	⊙	⊙	⊙	⊙	⊙	⊙	⊙	⊙	⊙	⊙
	100/112	---	⊙	⊙	⊙	⊙	⊙	⊙	⊙	⊙	⊙	⊙	⊙
	132	---	○	○	○	○	○	○	○	○	○	○	○
*130	100/112	---	○	○	○	○	○	○	○	○	○	○	○
	132	---	○	○	○	○	○	○	---	---	---	---	---
*150	100/112	---	○	○	○	○	○	○	○	○	○	○	○
	132	---	○	○	○	○	○	○	○	○	○	---	---
	160	---	○	○	○	○	○	○	○	---	---	---	---

\* RS only

- ⊙ - B5 & B14 (Elastic coupling G)
- ⊙ - B5 (Elastic coupling G)
- - B5 & B14 (IEC Bore)
- - B5 (IEC Bore)



# FRA - FTA

# Gearboxes Series RS & RT

## Motor frames

FRA FTA	IEC *	i = 7 **	10 **	15 **	20 **	28 **	40 **	49 **	56 **	70 **	80 **	100 **
63/40	56 B5&B14	①	①	①	①	①	①	①	①	①	①	①
63/50		①	①	①	①	①	①	①	①	①	①	①
63/60		---	---	---	---	①	①	①	①	①	①	①
63/40	63 B5&B14	①	①	①	①	①	①	①	①	①	①	①
63/50		①	①	①	①	①	①	①	①	①	①	①
63/60		---	---	---	---	①	①	①	①	①	①	①
71/50	71 B5&B14	②	②	②	②	②	②	②	---	---	---	---
71/60		②	②	②	②	②	②	②	②	②	②	②
71/70		②	②	②	②	②	②	②	②	②	②	②
71/85		---	---	---	---	---	②	②	②	②	②	②
80/60	80 B5&B14	③	③	③	③	③	---	---	---	---	---	---
80/70		③	③	③	③	③	③	③	---	---	---	---
80/85		③	③	③	③	③	③	③	③	③	③	③
80/110		④	④	④	④	③	③	③	③	③	③	③
80/60	90 B5&B14	③	③	③	③	③	---	---	---	---	---	---
80/70		③	③	③	③	③	③	③	---	---	---	---
80/85		③	③	③	③	③	③	③	③	③	③	③
80/110		④	④	④	④	③	③	③	③	③	③	③
100/110		④	④	④	④	③	③	③	③	③	③	③
100/130 ***	90 B5	⑤	⑤	⑤	⑤	⑤	⑤	⑤	⑤	⑤	⑤	⑤
	100 B5	⑤	⑤	⑤	⑤	⑤	⑤	⑤	⑤	⑤	⑤	⑤
100/150 ***	90 B5	⑥	⑥	⑥	⑤	⑤	⑤	⑤	⑤	⑤	⑤	⑤
	100 B5	⑥	⑥	⑥	⑤	⑤	⑤	⑤	⑤	⑤	⑤	⑤

\* - Helical stage input

\*\* - Helical stage output & FRS/FRT input

\*\*\* - FRA only

① -  $\varnothing 105 \times 14$

② -  $\varnothing 120 \times 19$

③ -  $\varnothing 140 \times 24$

④ -  $\varnothing 140 \times 28$

⑤ -  $\varnothing 200 \times 28$

⑥ -  $\varnothing 200 \times 28$  (Wormshaft bore  $\varnothing 38$  mm + Adapter  $\varnothing 38/\varnothing 28$ )

# Gearboxes Series RS & RT

## 2800 min<sup>-1</sup>

### Selection table

### Single worm gear boxes RS - RT

RS RT	i =	5	7	10	15	20	28	40	49	56	70	80	100
	min <sup>-1</sup>	560	400	280	187	140	100	70	57	50	40	35	28
28	kW	---	0.63	0.49	0.35	0.25	0.23	0.16	0.13	0.12	0.09	0.08	0.04
	Nm	---	13	14	14	13	15	14	13	12	11	10	7
	eff.	---	0.86	0.83	0.79	0.77	0.69	0.64	0.61	0.54	0.49	0.49	0.46
40	kW	2.1	1,5	1,2	0,82	0,56	0,49	0,36	0,30	0,26	0,21	0,19	0,15
	Nm	32	31	34	34	30	34	32	31	30	29	28	26
	eff.	0.89	0,87	0,85	0,81	0,78	0,72	0,66	0,62	0,6	0,57	0,54	0,51
50	kW	3.8	3,0	2,0	1,5	0,95	0,92	0,63	0,51	0,43	0,33	0,31	0,23
	Nm	58	62	59	61	52	66	59	56	53	46	49	40
	eff.	0.90	0,88	0,86	0,82	0,8	0,75	0,69	0,66	0,64	0,58	0,58	0,52
60	kW	5.8	4,4	3,5	2,6	1,9	1,6	1,1	0,72	0,73	0,60	0,52	0,34
	Nm	90	93	104	110	108	116	105	85	92	92	85	68
	eff.	0.90	0,88	0,87	0,84	0,82	0,76	0,73	0,71	0,66	0,64	0,6	0,58
70	kW	8.1	5,7	4,3	3,2	2,4	2,2	1,5	1,2	1,0	0,80	0,69	0,54
	Nm	126	122	130	139	136	161	155	142	130	120	115	107
	eff.	0.91	0,89	0,88	0,85	0,83	0,78	0,74	0,7	0,68	0,63	0,61	0,58
85	kW	13.0	9,6	7,5	5,3	4,3	3,1	2,4	2,0	1,7	1,3	1,1	0,93
	Nm	202	205	225	234	237	235	250	242	229	210	200	190
	eff.	0.91	0,89	0,88	0,86	0,8	0,8	0,76	0,72	0,71	0,67	0,64	0,6
110	kW	---	17,5	14,8	10,7	8,6	7,0	5,0	4,5	3,6	3,1	3,0	2,1
	Nm	---	375	445	470	490	530	520	545	490	525	540	450
	eff.	---	0,9	0,88	0,86	0,84	0,79	0,76	0,73	0,71	0,7	0,67	0,62
*130	kW	---	26.3	21.6	15.8	12.2	9.4	7.7	6.0	5.3	3.9	3.3	2.4
	Nm	---	565	655	705	715	715	815	740	780	670	620	560
	eff.	---	0.9	0.89	0.87	0.86	0.8	0.78	0.74	0.77	0.72	0.68	0.68
*150	kW	---	37.0	29.6	22.8	17.1	13.6	10.7	8.5	6.6	5.5	4.9	3.6
	Nm	---	795	900	1015	1005	1065	1170	1090	970	950	915	845
	eff.	---	0.9	0.89	0.87	0.86	0.82	0.8	0.77	0.77	0.72	0.68	0.68

\* RS only

**1400 min<sup>-1</sup>**

**Gearboxes Series RS & RT**

**Single worm gear boxes RS - RT**

**Selection table**

RS RT	i = min <sup>-1</sup>	5	7	10	15	20	28	40	49	56	70	80	100
		280	200	140	93	70	50	35	29	25	20	18	14
28	kW	---	0,45	0,33	0,23	0,16	0,16	0,10	0,09	0,08	0,06	0,05	0,03
	Nm	---	18	18	18	16	20	17	17	15	12	12	8
	eff.	---	0.84	0.81	0.77	0.74	0.66	0.62	0.57	0.51	0.45	0.45	0.43
40	kW	1.5	1,1	0,81	0,55	0,38	0,37	0,25	0,21	0,18	0,14	0,12	0,09
	Nm	45	45	46	44	39	48	42	41	38	36	32	29
	eff.	0.87	0.85	0.83	0.78	0.75	0.68	0.61	0.58	0.56	0.52	0.50	0.46
50	kW	2.7	1,8	1,3	0,93	0,63	0,63	0,41	0,37	0,31	0,25	0,20	0,13
	Nm	81	75	75	74	65	85	72	76	71	63	58	43
	eff.	0.88	0.86	0.84	0.78	0.76	0.71	0.64	0.62	0.60	0.53	0.52	0.47
60	kW	4.1	2,8	2,3	1,6	1,2	1,0	0,75	0,62	0,54	0,46	0,37	0,25
	Nm	125	113	133	130	122	139	135	128	123	122	106	83
	eff.	0.89	0.86	0.84	0.81	0.77	0.71	0.66	0.62	0.60	0.55	0.53	0.49
70	kW	5.7	4,0	3,1	2,2	1,8	1,5	1,2	0,84	0,74	0,58	0,50	0,37
	Nm	176	166	180	188	194	216	238	189	180	163	154	130
	eff.	0.89	0.88	0.86	0.83	0.81	0.75	0.71	0.67	0.64	0.59	0.56	0.52
85	kW	9.1	6,2	4,6	3,4	2,9	2,2	2,0	1,4	1,2	0,96	0,86	0,55
	Nm	279	259	268	289	322	319	401	316	305	290	280	210
	eff.	0.90	0.88	0.86	0.83	0.82	0.76	0.72	0.67	0.68	0.63	0.60	0.56
110	kW	---	12,5	9,0	6,5	5,7	4,4	3,5	2,7	2,2	2,0	1,5	1,1
	Nm	---	525	532	560	647	642	691	631	595	635	525	469
	eff.	---	0.88	0.87	0.84	0.83	0.76	0.73	0.71	0.70	0.67	0.66	0.61
*130	kW	---	19.0	15.0	11.0	8,5	7,5	5,5	3,9	3,7	2,7	2,4	1,8
	Nm	---	807	890	960	975	1100	1140	950	1005	865	810	750
	eff.	---	0.89	0.87	0.85	0.84	0.77	0.76	0.72	0.71	0.67	0.63	0.61
*150	kW	---	24.9	21.0	16.0	12,5	9,5	8,0	5,9	5,1	3,8	3,3	2,6
	Nm	---	1060	1260	1410	1430	1435	1680	1440	1420	1230	1170	1120
	eff.	---	0.89	0.88	0.86	0.84	0.79	0.77	0.73	0.73	0.68	0.65	0.63

\* RS only

# Gearboxes Series RS & RT

## 900 min<sup>-1</sup>

### Selection table

### Single worm gear boxes RS - RT

RS RT	i =	5	7	10	15	20	28	40	49	56	70	80	100
	min <sup>-1</sup>	180	128	90	60	45	32	23	19	16	13	11	9
28	kW	---	0,36	0,24	0,18	0,13	0,12	0,08	0,07	0,06	0,04	0,03	0,02
	Nm	---	22	20	21	19	22	20	19	16	13	11	8
	eff.	---	0,82	0,78	0,72	0,70	0,61	0,56	0,52	0,45	0,43	0,40	0,37
40	kW	1,2	0,84	0,64	0,44	0,30	0,28	0,19	0,16	0,14	0,12	0,10	0,08
	Nm	54	52	54	52	45	52	46	43	41	40	39	36
	eff.	0,86	0,83	0,80	0,74	0,70	0,63	0,56	0,52	0,49	0,46	0,44	0,42
50	kW	2,1	1,5	1,1	0,75	0,52	0,51	0,35	0,28	0,25	0,19	0,17	0,12
	Nm	96	95	95	91	79	99	85	81	80	67	67	55
	eff.	0,86	0,85	0,81	0,76	0,72	0,65	0,58	0,56	0,54	0,47	0,46	0,42
60	kW	3,2	2,4	1,9	1,4	1,0	0,87	0,56	0,43	0,40	0,32	0,28	0,19
	Nm	150	150	163	166	161	175	152	135	130	125	115	94
	eff.	0,87	0,85	0,83	0,75	0,76	0,68	0,64	0,61	0,55	0,53	0,480	0,47
70	kW	4,5	3,2	2,4	1,7	1,3	1,2	0,87	0,64	0,53	0,42	0,38	0,30
	Nm	212	202	211	218	207	242	240	205	187	170	160	147
	eff.	0,88	0,86	0,83	0,79	0,77	0,70	0,654	0,62	0,59	0,54	0,50	0,46
85	kW	7,2	5,0	3,9	3,0	2,1	1,8	1,5	1,0	0,83	0,73	0,64	0,51
	Nm	338	320	350	378	355	373	410	350	332	300	290	260
	eff.	0,88	0,86	0,84	0,80	0,78	0,71	0,66	0,672	0,671	0,55	0,53	0,48
110	kW	---	9,8	8,0	5,7	4,4	3,7	2,7	2,3	1,9	1,7	1,5	0,94
	Nm	---	635	720	745	745	795	780	780	690	765	715	500
	eff.	---	0,87	0,85	0,82	0,79	0,73	0,68	0,64	0,62	0,59	0,57	0,50
*130	kW	---	14,9	11,7	8,4	6,5	5,1	4,1	3,1	2,8	2,1	1,8	1,3
	Nm	---	975	1070	1115	1115	1145	1215	1095	1145	960	890	805
	eff.	---	0,88	0,86	0,83	0,81	0,75	0,70	0,67	0,68	0,63	0,58	0,57
*150	kW	---	20,8	15,9	12,2	9,3	7,3	5,6	4,5	3,3	2,9	2,5	2,0
	Nm	---	1360	1470	1635	1625	1660	1740	1600	1370	1390	1290	1230
	eff.	---	0,88	0,87	0,84	0,82	0,77	0,73	0,69	0,69	0,64	0,61	0,58

\* RS only

**700 min<sup>-1</sup>**

**Gearboxes Series RS & RT**

**Single worm gear boxes RS - RT**

**Selection table**

RS RT	i =	5	7	10	15	20	28	40	49	56	70	80	100
	min <sup>-1</sup>	140	100	70	47	35	25	18	15	13	10	8.7	7
28	kW	---	0,29	0,21	0,14	0,10	0,10	0,06	0,05	0,04	0,03	0,02	0,01
	Nm	---	23	23	22	21	24	21	20	17	13	11	8
	eff.	---	0.81	0.77	0.71	0.69	0.60	0.55	0.51	0.44	0.40	0.39	0.36
40	kW	1.00	0,74	0,54	0,39	0,26	0,24	0,17	0,14	0,12	0,10	0,09	0,07
	Nm	59	58	58	58	49	55	49	46	45	43	41	38
	eff.	0.85	0.82	0.79	0.73	0.68	0.59	0.53	0.50	0.48	0.44	0.42	0.39
50	kW	1.8	1,4	0,92	0,65	0,44	0,43	0,29	0,24	0,21	0,16	0,15	0,12
	Nm	106	110	100	99	86	106	91	87	83	70	72	62
	eff.	0.86	0.83	0.80	0.75	0.71	0.64	0.57	0.542	0.52	0.45	0.44	0.39
60	kW	2.8	2,0	1,6	1,1	0,87	0,73	0,49	0,35	0,34	0,26	0,24	0,17
	Nm	165	164	177	178	175	187	165	140	139	128	120	100
	eff.	0.87	0.84	0.81	0.77	0.74	0.67	0.62	0.59	0.54	0.51	0.46	0.44
70	kW	3.9	2,7	2,1	1,4	1,1	1,0	0,71	0,55	0,46	0,36	0,32	0,24
	Nm	234	216	233	231	225	256	245	220	197	176	167	150
	eff.	0.87	0.85	0.82	0.78	0.75	0.68	0.63	0.60	0.56	0.51	0.48	0.45
85	kW	6.2	4,6	3,5	2,5	1,9	1,5	1,2	0,93	0,78	0,59	0,56	0,44
	Nm	372	370	400	408	388	400	420	379	353	310	305	275
	eff.	0.87	0.85	0.83	0.79	0.76	0.69	0.65	0.61	0.59	0.55	0.50	0.46
110	kW	---	8,5	6,8	4,9	3,9	3,3	2,3	2,0	1,7	1,5	1,2	0,79
	Nm	---	700	780	795	815	890	820	840	770	815	720	515
	eff.	---	0.86	0.84	0.80	0.77	0.71	0.66	0.62	0.60	0.57	0.55	0.48
*130	kW	---	12,8	10,3	7,4	5,6	4,4	3,6	2,7	2,4	1,8	1,6	1,1
	Nm	---	1060	1200	1230	1215	1200	1320	1185	1215	1030	955	855
	eff.	---	0.87	0.85	0.81	0.80	0.72	0.68	0.65	0.66	0.61	0.56	0.55
*150	kW	---	18,0	13,7	10,6	8,1	6,2	4,9	3,8	3,0	2,6	2,3	1,7
	Nm	---	1475	1610	1805	1780	1790	1890	1710	1535	1500	1425	1275
	eff.	---	0.87	0.86	0.83	0.81	0.75	0.71	0.68	0.67	0.61	0.58	0.56

\* RS only

# Gearboxes Series RS & RT

## 1400 min<sup>-1</sup>

### Selection table

### Helical worm gear boxes RA - TA

	$i_1 =$	3.5	6.3	8
	min <sup>-1</sup>	400	225	175
XA63	kW	0.50	0.23	0.18
	Nm	12	10	9
	R <sub>2</sub> [N]	390	450	450
XA71	kW	1.1	0.52	0.37
	Nm	26	22	20
	R <sub>2</sub> [N]	490	560	560
XA80	kW	3.1	1.5	1.1
	Nm	68	65	60
	R <sub>2</sub> [N]	610	700	700
XA100	kW	8.7	4.0	2.2
	Nm	235	163	136
	R <sub>2</sub> [N]	1500	2500	2500

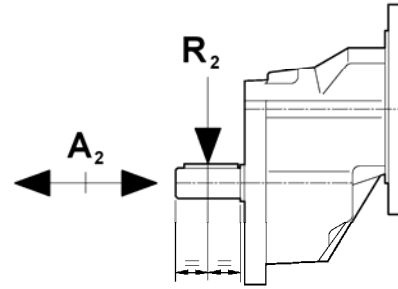

$$A_2 = 0.2 \times R_2$$

Dimensions: page 52

<b><math>i_1 = 3.5</math></b>	$i = i_1 \times i_2$	25	35	53	70	98	140	172	196	245	280	350
	min <sup>-1</sup>	57	40	27	20	14	10	8	7	6	5	4
	$i_2$	7	10	15	20	28	40	49	56	70	80	100
63/40	kW	0.55	0.40	0.28	0.20	0.19	0.13	0.11	0.10	0.06	0.05	0.03
	Nm	72	72	70	60	70	64	58	56	42	35	25
	eff.	0.78	0.75	0.70	0.63	0.56	0.50	0.46	0.44	0.41	0.40	0.35
63/50	kW	1.02	0.70	0.50	0.33	0.32	0.21	0.20	0.16	0.11	0.09	0.06
	Nm	135	127	125	105	125	105	115	100	80	70	50
	eff.	0.79	0.76	0.70	0.66	0.59	0.52	0.50	0.46	0.42	0.40	0.35
63/60	kW	1.53	1.18	0.83	0.57	0.53	0.33	0.27	0.23	0.19	0.15	0.10
	Nm	205	217	215	192	217	177	170	152	145	110	85
	eff.	0.80	0.77	0.72	0.70	0.61	0.57	0.54	0.49	0.45	0.38	0.36
71/70	kW	1.96	1.48	1.08	0.77	0.72	0.50	0.43	0.36	0.30	0.26	0.19
	Nm	265	275	285	260	310	270	270	235	225	200	180
	eff.	0.81	0.78	0.74	0.71	0.64	0.57	0.54	0.49	0.45	0.41	0.39
71/85	kW	3.14	2.39	1.77	1.37	1.11	0.80	0.65	0.58	0.49	0.40	0.26
	Nm	430	450	475	470	475	445	420	410	390	340	250
	eff.	0.82	0.79	0.75	0.72	0.64	0.58	0.55	0.53	0.48	0.44	0.40
80/110	kW	6.02	4.63	3.58	2.61	2.18	1.60	1.27	1.12	0.86	0.86	0.54
	Nm	835	895	950	910	960	950	850	820	750	740	540
	eff.	0.83	0.81	0.74	0.73	0.66	0.62	0.57	0.55	0.52	0.45	0.42
RA 100/130	kW	7.0	6.8	5.5	3.8	3.1	2.3	1.7	1.5	1.3	1.1	0.8
	Nm	975	1320	1495	1350	1430	1380	1300	1250	1200	1080	880
	eff.	0.83	0.81	0.77	0.75	0.67	0.63	0.64	0.62	0.60	0.50	0.48
RA 100/150	kW	7.9	7.8	7.5	5.7	4.5	3.3	2.7	2.4	1.8	1.6	1.0
	Nm	1115	1535	2090	2060	2130	2050	2040	2025	1700	1459	1200
	eff.	0.84	0.82	0.79	0.76	0.69	0.66	0.64	0.62	0.60	0.52	0.50

**1400 min<sup>-1</sup>**

**Gearboxes Series RS & RT**

**Helical worm gear boxes RA - TA**

**Selection table**

<b>i<sub>1</sub> = 6.3</b>	<b>i = i<sub>1</sub> x i<sub>2</sub></b>	44	63	95	126	176	252	309	353	441	504	630
	<b>min<sup>-1</sup></b>	32	22	15	11	8	5.5	4.6	4	3.2	2.8	2.2
	<b>i<sub>2</sub></b>	7	10	15	20	28	40	49	56	70	80	100
63/40	<b>kW</b>	0.35	0.25	0.17	0.12	0.11	0.08	0.06	0.06	0.05	0.04	0.03
	<b>Nm</b>	79	78	74	63	69	63	57	55	53	51	46
	<b>eff.</b>	0.76	0.72	0.67	0.60	0.52	0.45	0.43	0.39	0.35	0.34	0.31
63/50 71/50	<b>kW</b>	0.62	0.42	0.30	0.20	0.20	0.14	0.11	0.10	0.09	0.07	0.05
	<b>Nm</b>	145	133	130	113	138	115	108	100	92	89	72
	<b>eff.</b>	0.78	0.74	0.67	0.63	0.55	0.48	0.45	0.42	0.36	0.36	0.31
63/60 71/60 80/60	<b>kW</b>	0.92	0.74	0.52	0.40	0.35	0.23	0.16	0.16	0.11	0.10	0.08
	<b>Nm</b>	218	237	235	230	238	210	160	175	141	130	122
	<b>eff.</b>	0.79	0.75	0.70	0.67	0.57	0.53	0.49	0.45	0.42	0.37	0.35
71/70 80/70	<b>kW</b>	1.2	0.95	0.68	0.50	0.44	0.32	0.26	0.23	0.18	0.17	0.12
	<b>Nm</b>	289	310	310	292	320	295	272	254	221	210	190
	<b>eff.</b>	0.80	0.76	0.71	0.68	0.60	0.54	0.50	0.46	0.42	0.37	0.36
71/85 80/85	<b>kW</b>	2.0	1.6	1.1	0.84	0.69	0.53	0.43	0.37	0.28	0.26	0.22
	<b>Nm</b>	490	526	516	495	501	500	466	449	391	380	345
	<b>eff.</b>	0.80	0.77	0.72	0.69	0.60	0.55	0.51	0.50	0.46	0.42	0.36
80/110 100/110	<b>kW</b>	4.3	3.2	2.4	1.8	1.6	1.1	1.0	0.80	0.66	0.51	0.32
	<b>Nm</b>	1030	1100	1150	100	1170	1110	1100	995	950	780	550
	<b>eff.</b>	0.81	0.79	0.74	0.71	0.63	0.57	0.53	0.52	0.48	0.45	0.39
RA 100/130	<b>kW</b>	6.41	4.94	3.72	2.71	2.37	1.65	1.47	1.25	1.02	0.82	0.47
	<b>Nm</b>	1600	1700	1800	1700	1800	1700	1700	1600	1600	1300	900
	<b>eff.</b>	0.83	0.80	0.75	0.73	0.63	0.60	0.55	0.53	0.52	0.46	0.45
RA 100/150	<b>kW</b>	8.41	6.61	5.04	3.77	3.02	2.31	1.82	1.41	1.24	1.09	0.84
	<b>Nm</b>	2100	2300	2500	2400	2400	2500	2300	2000	1800	1800	1700
	<b>eff.</b>	0.83	0.81	0.77	0.74	0.66	0.63	0.60	0.59	0.81	0.48	0.47



# Gearboxes Series RS & RT

# 1400 min<sup>-1</sup>

## Selection table

## Helical worm gear boxes RA - TA

$i_1 = 8$	$i = i_1 \times i_2$ min <sup>-1</sup>	56	80	120	160	224	320	392	448	560	640	800
	$i_2$	25	18	12	9	6	4	3.5	3	2.5	2.2	1.75
63/40	kW	0.32	0.23	0.16	0.11	0.11	0.08	0.06	0.05	0.03	0.03	0.02
	Nm	93	89	84	72	85	75	69	59	45	38	27
	eff.	0.75	0.72	0.65	0.59	0.50	0.44	0.41	0.38	0.36	0.34	0.31
63/50 71/50	kW	0.58	0.41	0.28	0.20	0.18	0.13	0.10	0.09	0.06	0.05	0.03
	Nm	170	165	154	130	150	130	120	115	86	73	53
	eff.	0.77	0.73	0.67	0.61	0.55	0.47	0.45	0.41	0.36	0.37	0.31
63/60 71/60 80/60	kW	0.87	0.68	0.49	0.34	0.31	0.21	0.16	0.15	0.10	0.08	0.05
	Nm	260	280	275	240	270	235	220	200	155	125	92
	eff.	0.78	0.75	0.69	0.65	0.57	0.51	0.50	0.43	0.41	0.37	0.35
71/70 80/70	kW	1.26	0.88	0.63	0.44	0.48	0.28	0.24	0.20	0.16	0.12	0.05
	Nm	380	365	360	325	440	320	320	275	245	200	145
	eff.	0.79	0.76	0.70	0.67	0.60	0.53	0.50	0.45	0.41	0.38	0.35
71/85 80/85	kW	1.76	1.42	1.07	0.85	0.65	0.48	0.40	0.33	0.26	0.20	0.13
	Nm	530	595	620	620	600	560	550	510	450	360	260
	eff.	0.79	0.77	0.71	0.67	0.60	0.54	0.52	0.50	0.45	0.41	0.37
80/110 100/110	kW	3.42	2.75	1.97	1.52	1.29	0.97	0.73	0.64	0.52	0.43	0.27
	Nm	1045	1170	1180	1160	1200	1180	1020	980	920	850	550
	eff.	0.80	0.78	0.73	0.70	0.61	0.56	0.52	0.50	0.46	0.45	0.38
RA 100/130	kW	3.3	3.0	3.2	2.3	1.8	1.2	1.1	0.9	0.7	0.7	0.5
	Nm	1000	1240	1840	1765	1760	1700	1660	1600	1435	1330	1160
	eff.	0.80	0.78	0.73	0.72	0.62	0.58	0.56	0.54	0.51	0.45	0.43
RA 100/150	kW	3.7	3.4	3.6	3.4	2.7	2.0	1.7	1.4	1.1	1.0	0.8
	Nm	1130	1425	2150	2580	2675	2860	2550	2490	2110	1970	1855
	eff.	0.81	0.79	0.75	0.72	0.63	0.61	0.56	0.57	0.49	0.46	0.45

**1400 min<sup>-1</sup>**

**Gearboxes Series RS & RT**

**Two stage worm gear boxes RS/RS - RT/RT**

**Selection table**

RS/RS RT/RT	$i = i_1 \times i_2$	420	560	784	1120	1568	2240	2800	4000	5600	8000	10000
	min <sup>-1</sup>	3.3	2.5	1.8	1.25	0.9	0.6	0.5	0.35	0.25	0.17	0.14
	$i_1 =$ $i_2 =$	15 28	20 28	28 28	40 28	56 28	56 40	70 40	100 40	100 56	100 80	100 100
28/28	W	32	25	21	16	13	9	8	6	3	1.8	1.3
	Nm	35	36	36	36	35	30	30	30	16	12	11
	eff.	0.38	0.37	0.32	0.30	0.25	0.21	0.20	0.18	0.14	0.12	0.13
28/40	W	75	60	46	34	30	22	22	14	11	5	3
	Nm	85	85	80	80	80	73	76	70	62	41	25
	eff.	0.39	0.37	0.33	0.31	0.25	0.21	0.18	0.18	0.15	0.14	0.12
28/50	W	133	106	91	74	60	36	36	28	20	10	6
	Nm	150	150	160	175	160	125	131	147	125	78	49
	eff.	0.39	0.37	0.33	0.31	0.25	0.22	0.19	0.19	0.16	0.14	0.12
28/60	W	197	157	132	91	91	67	54	30	32	16	10
	Nm	240	240	245	230	260	245	217	164	195	128	91
	eff.	0.42	0.40	0.35	0.33	0.27	0.23	0.21	0.20	0.16	0.14	0.13
40/70	W	298	249	198	157	119	86	72	60	42	24	16
	Nm	380	400	400	395	380	370	345	360	321	201	154
	eff.	0.44	0.42	0.38	0.33	0.30	0.27	0.25	0.22	0.20	0.15	0.14
40/85	W	447	372	276	224	180	138	120	90	72	39	26
	Nm	595	625	585	625	610	615	595	565	550	373	264
	eff.	0.46	0.44	0.40	0.35	0.32	0.28	0.26	0.23	0.20	0.17	0.15
50/110	W	865	756	579	453	382	292	235	163	128	82	51
	Nm	1190	1300	1300	1280	1350	1340	1210	1070	980	810	560
	eff.	0.48	0.45	0.42	0.37	0.33	0.30	0.27	0.24	0.20	0.18	0.16
RS/RS 60/130	kW	1.5	1.1	0.75	0.55	0.55	0.37	0.25	0.25	0.25	0.25	0.25
	Nm	2015	1930	1670	1530	2015	1830	1410	1770	1850	1420	1225
	eff.	0.50	0.46	0.43	0.40	0.35	0.33	0.30	0.27	0.25	0.21	0.20
RS/RS 70/150	kW	1.8	1.5	1.1	0.75	0.75	0.55	0.37	0.37	0.25	0.25	0.25
	Nm	2570	2830	2570	2460	2850	3020	2325	2875	2670	2135	1995
	eff.	0.52	0.50	0.46	0.43	0.39	0.36	0.33	0.31	0.27	0.23	0.22

# Gearboxes Series RS & RT

# 1400 min<sup>-1</sup>

## Selection table

## Geared motors

0.06 kW						0.09 kW					
	min <sup>-1</sup>	i =	Nm	SF	kg		min <sup>-1</sup>	i =	Nm	SF	kg
MRS-MRT 28	200	7	2.4	>3	3.6	MRS-MRT 40/85	0.4	4000	565	1.0	19
MRS-MRT 28	140	10	3.3	>3	3.6	MRS-MRT 40/85	0.3	5600	688	0.8	19
MRS-MRT 28	93	15	4.7	>3	3.6	<b>0.12 kW</b>					
MRS-MRT 28	70	20	6.1	2.6	3.6		min <sup>-1</sup>	i =	Nm	SF	kg
MRS-MRT 28	50	28	7.6	2.6	3.6	MRS-MRT 28	200	7	4.8	>3	4.8
MRS-MRT 28	35	40	10	1.7	3.6	MRS-MRT 28	140	10	6.6	2.7	4.8
MRA-MTA 63/40	32	44	14	>3	6.5	MRS-MRT 28	93	15	9.5	1.9	4.8
MRS-MRT 28	29	49	11	1.5	3.6	MRS-MRT 28	70	20	12	1.3	4.8
MRS-MRT 28	25	56	12	1.3	3.6	MRS-MRT 28	50	28	15	1.3	4.8
MRA-MTA 63/40	22	63	19	>3	6.5	MRS-MRT 40	35	40	20	2.1	6.2
MRS-MRT 28	20	70	13	0.9	3.6	MRA-MTA 63/40	32	44	27	2.9	7.7
MRS-MRT 40	18	80	16	2.0	5.0	MRS-MRT 40	29	49	23	1.8	6.2
MRA-MTA 63/40	15	95	26	2.8	6.5	MRS-MRT 40	25	56	26	1.5	6.2
MRS-MRT 40	14	100	19	1.5	5.0	MRA-MTA 63/40	22	63	37	2.1	7.7
MRA-MTA 63/40	11	126	31	2.0	6.5	MRS-MRT 40	20	70	30	1.2	6.2
MRS-MRT 28/28	9.3	150	31	1.1	5.0	MRS-MRT 40	18	80	33	1.0	6.2
MRA-MTA 63/40	8.0	176	37	1.8	6.5	MRA-MTA 63/40	15	95	52	1.4	7.7
MRS-MRT 28/28	7.0	200	30	0.8	5.0	MRS-MRT 50	14	100	38	1.1	7.5
MRA-MTA 63/40	5.5	252	46	1.4	6.5	MRA-MTA 63/40	11	126	62	1.0	7.7
MRS-MRT 28/28	5.0	280	35	0.8	5.0	MRS-MRT 28/40	9.3	150	64	1.4	7.6
MRA-MTA 63/40	4.6	309	54	1.0	6.5	MRA-MTA 63/40	8.0	176	75	0.9	7.7
MRA-MTA 63/40	4.0	353	56	1.0	6.5	MRS-MRT 28/40	7.0	200	77	1.0	7.6
MRS-MRT 28/40	3.3	420	67	1.3	6.4	MRA-MTA 63/50	5.5	252	99	1.2	9.0
MRA-MTA 63/50	3.2	441	65	1.4	7.8	MRS-MRT 28/40	5.0	280	94	0.8	7.6
MRA-MTA 63/50	2.8	504	74	1.2	7.8	MRA-MTA 63/50	4.6	309	114	0.9	9.0
MRS-MRT 28/40	2.5	560	85	1.0	6.4	MRS-MRT 28/50	3.3	420	134	1.2	8.9
MRA-MTA 63/50	2.2	630	80	0.9	7.8	MRS-MRT 28/50	2.5	560	170	0.9	8.9
MRS-MRT 28/50	1.8	784	106	1.5	7.7	MRS-MRT 28/60	1.8	784	225	1.1	12
MRS-MRT 28/50	1.3	1120	142	1.2	7.7	MRS-MRT 28/60	1.3	1120	303	0.8	12
MRS-MRT 28/50	0.9	1568	160	1.0	7.7	MRS-MRT 40/70	0.9	1568	385	1.0	16
MRS-MRT 28/60	0.6	2240	211	1.2	10	MRS-MRT 40/85	0.6	2240	513	1.2	20
MRS-MRT 28/60	0.5	2800	241	0.9	10	MRS-MRT 40/85	0.5	2800	596	1.0	20
MRS-MRT 40/70	0.4	4000	360	1.0	15	MRS-MRT 40/85	0.4	4000	753	0.8	20
MRS-MRT 40/70	0.3	5600	458	0.7	15	<b>0.18 kW</b>					
MRS-MRT 40/85	0.2	8000	557	0.7	19		min <sup>-1</sup>	i =	Nm	SF	kg
MRS-MRT 40/110	0.1	10000	614	0.4	19	MRS-MRT 28	200	7	7.2	2.5	5.4
<b>0.09 kW</b>						MRS-MRT 28	140	10	9.9	1.8	5.4
	min <sup>-1</sup>	i =	Nm	SF	kg	MRS-MRT 28	93	15	14	1.3	5.4
MRS-MRT 28	200	7	3.6	>3	3.7	MRS-MRT 40	70	20	18	2.1	6.8
MRS-MRT 28	140	10	5.0	>3	3.7	MRS-MRT 40	50	28	23	2.1	6.8
MRS-MRT 28	93	15	7.1	2.5	3.7	MRS-MRT 40	35	40	30	1.4	6.8
MRS-MRT 28	70	20	9.1	1.8	3.7	MRA-MTA 63/40	32	44	41	1.9	8.3
MRS-MRT 28	50	28	11	1.8	3.7	MRS-MRT 40	29	49	35	1.2	6.8
MRS-MRT 28	35	40	15	1.1	3.7	MRS-MRT 40	25	56	39	1.0	6.8
MRA-MTA 63/40	32	44	21	>3	6.6	MRA-MTA 63/40	22	63	56	1.4	8.3
MRS-MRT 28	29	49	17	1.0	3.7	MRS-MRT 50	20	70	46	1.4	8.1
MRS-MRT 40	25	56	20	2.1	5.1	MRS-MRT 50	18	80	51	1.1	8.1
MRA-MTA 63/40	22	63	28	2.8	6.6	MRA-MTA 63/40	15	95	78	0.9	8.3
MRS-MRT 40	20	70	22	1.6	5.1	MRA-MTA 63/50	11	126	97	1.2	9.6
MRS-MRT 40	18	80	25	1.3	5.1	MRS-MRT 28/50	9.3	150	93	1.6	9.5
MRA-MTA 63/40	15	95	39	1.9	6.6	MRA-MTA 63/50	8.0	176	119	1.2	9.6
MRS-MRT 40	14	100	28	1.0	5.1	MRS-MRT 28/50	7.0	200	120	1.1	9.5
MRA-MTA 63/40	11	126	46	1.4	6.6	MRS-MRT 28/50	5.0	280	141	1.1	9.5
MRS-MRT 28/40	9.3	150	48	1.3	6.5	MRS-MRT 28/60	3.3	420	217	1.1	12
MRA-MTA 63/40	8.0	176	56	1.2	6.6	MRS-MRT 40/70	2.5	560	289	1.4	16
MRS-MRT 28/40	7.0	200	60	1.3	6.5	MRS-MRT 40/70	1.8	784	366	1.1	16
MRA-MTA 63/40	5.5	252	70	0.9	6.6	MRS-MRT 40/85	1.3	1120	481	1.3	21
MRS-MRT 28/40	5.0	280	70	1.0	6.5	MRS-MRT 40/85	0.9	1568	616	1.0	21
MRA-MTA 63/50	4.6	309	86	1.3	7.9	MRS-MRT 40/85	0.6	2240	770	0.8	21
MRA-MTA 63/50	4.0	353	91	1.1	7.9	<b>0.25 kW</b>					
MRS-MRT 28/50	3.3	420	101	1.5	7.8		min <sup>-1</sup>	i =	Nm	SF	kg
MRA-MTA 63/50	3.2	441	97	0.9	7.9	MRS-MRT 40	280	5	7.5	>3	8.3
MRS-MRT 28/50	2.5	560	127	1.2	7.8	MRS-MRT 40	200	7	10	>3	8.3
MRS-MRT 28/50	1.8	784	159	1.0	7.8	MRS-MRT 40	140	10	14	>3	8.3
MRS-MRT 28/50	1.3	1120	213	0.8	7.8	MRS-MRT 40	93	15	20	2.2	8.3
MRS-MRT 28/60	0.9	1568	260	1.0	11	MRS-MRT 40	70	20	26	1.5	8.3
MRS-MRT 40/70	0.6	2240	371	1.0	15	MRS-MRT 40	50	28	32	1.5	8.3
MRS-MRT 40/85	0.5	2800	447	1.3	19	MRS-MRT 40	35	40	42	1.0	8.3

1400 min<sup>-1</sup>

Gearboxes Series RS & RT

Geared motors

Selection table

0.25 kW	min <sup>-1</sup>	i =	Nm	SF	kg	0.55 kW	min <sup>-1</sup>	i =	Nm	SF	kg
MRA-MTA 71/50	32	44	59	2.5	12	MRA-MTA 80/85	8.0	176	396	1.3	26
MRS-MRT 50	29	49	52	1.5	9.6	MRA-MTA 80/85	5.5	252	520	1.0	26
MRS-MRT 50	25	56	57	1.3	9.6	MRA-MTA 80/110	4.6	309	614	1.8	49
MRA-MTA 71/50	22	63	80	1.7	12	MRA-MTA 80/110	4.0	353	689	1.4	49
MRS-MRT 50	20	70	63	1.0	9.6	MRS-MRT 50/110	3.3	420	756	1.1	49
MRS-MRT 60	18	80	72	1.5	12	MRA-MTA 80/110	3.2	441	794	1.2	49
MRA-MTA 71/50	95	95	109	1.2	12	MRA-MTA 80/110	2.8	504	851	0.9	49
MRS-MRT 60	14	100	88	1.0	12	MRS-MRT 50/110	2.5	570	962	1.3	49
MRA-MTA 71/60	11	126	144	1.6	15	MRS-MRT 50/110	1.8	784	1235	1.5	49
MRS-MRT 40/70	9.3	150	146	1.5	18						
MRA-MTA 71/60	8.0	176	171	1.4	15	0.75 kW	min <sup>-1</sup>	i =	Nm	SF	kg
MRS-MRT 40/70	7.0	200	188	1.5	18	MRS-MRT 50	280	5	23	>3	14
MRA-MTA 71/70	5.5	252	232	1.3	18	MRS-MRT 50	200	7	31	2.4	14
MRS-MRT 40/70	5.0	280	224	1.5	18	MRS-MRT 50	140	10	43	1.7	14
MRA-MTA 71/70	4.6	309	263	1.0	18	MRS-MRT 50	93	15	60	1.2	14
MRA-MTA 71/70	4.0	353	277	0.9	18	MRS-MRT 60	70	20	79	1.5	17
MRS-MRT 40/70	3.3	420	315	1.2	18	MRS-MRT 60	50	28	102	1.4	17
MRS-MRT 40/70	2.5	560	401	1.0	18	MRS-MRT 60	35	40	135	1.0	17
MRS-MRT 40/85	1.8	784	535	1.1	22	MRA-MTA 80/60	32	44	178	1.2	20
MRS-MRT 50/110	1.3	1120	707	1.8	46	MRS-MRT 70	29	49	168	1.1	19
MRS-MRT 50/110	0.9	1568	882	1.5	46	MRS-MRT 70	25	56	183	1.0	19
MRS-MRT 50/110	0.6	2240	1146	1.2	46	MRA-MTA 80/60	22	63	242	1.0	20
MRS-MRT 50/110	0.5	2800	1289	0.9	46	MRS-MRT 85	20	70	226	1.3	23
						MRS-MRT 85	18	80	246	1.1	23
0.37 kW	min <sup>-1</sup>	i =	Nm	SF	kg	MRA-MTA 80/70	11	126	341	0.9	23
MRS-MRT 40	280	5	11	>3	8.7	MRA-MTA 80/85	8.0	176	540	0.9	27
MRS-MRT 40	200	7	15	3.0	8.7	MRA-MTA 80/110	5.5	252	735	1.5	50
MRS-MRT 40	140	10	21	2.2	8.7	MRA-MTA 80/110	4.6	309	838	1.3	50
MRS-MRT 40	93	15	30	1.5	8.7	MRA-MTA 80/110	4.0	353	939	1.1	50
MRS-MRT 40	70	20	38	1.0	8.7	MRS-MRT 50/110	3.3	420	1031	1.2	50
MRS-MRT 40	50	28	48	1.0	8.7	MRA-MRT 80/110	3.2	441	1083	0.9	50
MRS-MRT 50	35	40	65	1.1	10	MRS-MRT 50/110	2.5	570	1289	1.0	50
MRA-MTA 71/50	32	44	87	1.7	13						
MRS-MRT 50	29	49	77	1.0	10	1.1 kW	min <sup>-1</sup>	i =	Nm	SF	kg
MRS-MRT 60	25	56	85	1.5	13	MRS-MRT 60	280	5	34	>3	19
MRA-MTA 71/50	22	63	118	1.1	13	MRS-MRT 60	200	7	45	2.5	19
MRS-MRT 60	20	70	97	1.3	13	MRS-MRT 60	140	10	63	2.1	19
MRS-MRT 60	18	80	107	1.0	13	MRS-MRT 60	93	15	91	1.4	19
MRA-MTA 71/60	15	95	168	1.4	16	MRS-MRT 60	70	20	116	1.1	19
MRS-MRT 70	14	100	130	1.0	15	MRS-MRT 70	50	28	158	1.4	21
MRA-MTA 71/60	11	126	213	1.1	15	MRS-MRT 70	35	40	213	1.1	21
MRS-MRT 40/70	9.3	150	217	2.1	18	MRA-MTA 80/70	32	44	264	1.1	25
MRA-MTA 71/60	8.0	176	253	0.9	15	MRS-MRT 85	29	49	24	1.	26
MRS-MRT 40/70	7.0	200	278	1.3	18	MRS-MRT 85	25	56	286	1.1	26
MRA-MTA 71/70	5.5	252	343	0.9	18	MRA-MTA 80/85	22	63	364	1.4	30
MRS-MRT 40/70	5.0	280	332	1.1	18	MRS-MRT 110	20	70	352	1.8	48
MRS-MRT 40/85	3.3	420	488	1.2	23	MRS-MRT 110	18	80	396	1.3	48
MRS-MRT 40/85	2.5	560	622	1.0	23	MRA-MTA 80/85	15	95	513	1.0	30
MRS-MRT 50/110	1.3	1120	1046	1.2	47	MRS-MRT 110	14	100	458	1.0	48
MRS-MRT 50/110	0.9	1568	1306	1.1	47	MRA-MTA 80/110	11	126	671	1.6	52
						MRA-MTA 80/110	8.0	176	832	1.4	52
0.55 kW	min <sup>-1</sup>	i =	Nm	SF	kg	MRA-MRT 80/110	5.5	252	1078	1.0	52
MRS-MRT 40	280	5	16	2.8	10.7	MRA-MTA 80/110	4.6	309	1229	0.9	52
MRS-MRT 50	200	7	23	>3	12	MRA 100/130	3.5	400	1681	1.0	76
MRS-MRT 50	140	10	32	2.4	12	MRS-MRT 60/130	3.3	420	1576	1.3	69
MRS-MRT 50	93	15	44	1.7	12	MRA 100/150	3.0	448	1916	1.3	106
MRS-MRT 50	70	20	57	1.1	12	MRA 100/150	2.5	560	2059	1.0	106
MRS-MRT 50	50	28	75	1.1	12	MRA 100/150	2.2	640	2209	0.9	106
MRS-MRT 60	35	40	99	1.4	15	MRS-MRT 70/150	1.8	784	2706	0.9	102
MRA-MTA 80/60	32	44	130	1.7	19						
MRS-MRT 60	29	49	114	1.1	15	1.5 kW	min <sup>-1</sup>	i =	Nm	SF	kg
MRS-MRT 60	25	56	126	1.0	15	MRS-MRT 60	280	5	46	2.7	20
MRA-MTA 80/60	22	63	177	1.2	19	MRS-MRT 60	200	7	62	1.8	20
MRS-MRT 70	20	70	155	1.1	18	MRS-MRT 60	140	10	86	1.5	20
MRS-MRT 70	18	80	168	1.0	18	MRS-MRT 60	93	15	124	1.0	20
MRA-MTA 80/60	15	95	249	1.0	19	MRS-MRT 70	70	20	166	1.2	23
MRS-MRT 85	14	100	210	1.0	22	MRS-MRT 70	50	28	215	1.0	23
MRA-MTA 80/70	11	126	321	1.1	22	MRS-MRT 85	35	40	295	1.4	27

# Gearboxes Series RS & RT

# 1400 min<sup>-1</sup>

## Selection table

## Geared motors

1.5 kW						4.0 kW					
	min <sup>-1</sup>	i =	Nm	SF	kg		min <sup>-1</sup>	i =	Nm	SF	kg
MRA-MTA 80/85	32	44	360	1.4	31	MRS 150	25	56	1115	1.3	130
MRS-MRT 85	29	49	336	0.9	27	MRS 150	20	70	1299	0.9	130
MRS-MRT 110	29	49	356	1.8	50	MRA 100/130	20	70	1433	0.9	93
MRS-MRT 110	25	56	401	1.5	50	MRA 100/150	18	80	1724	0.9	123
MRA-MTA 80/85	22	63	496	1.1	31	MRA 100/150	14	98	1845	1.2	123
MRS-MRT 110	20	70	480	1.3	50	MRA 100/150	12	120	2456	0.9	123
MRS-MRT 110	18	80	540	1.0	50	<b>5.5 kW</b>					
MRA-MTA 80/110	15	95	719	1.6	54		min <sup>-1</sup>	i =	Nm	SF	kg
MRS 130	14	100	624	1.2	64	MRS-MRT 110	200	7	231	2.3	79
MRA-MTA 80/110	11	126	915	1.2	54	MRS-MRT 110	140	10	326	1.6	79
MRA-MTA 80/110	8.0	176	1135	1.0	54	MRS-MRT 110	93	15	473	1.2	79
MRA 100/130	7.0	200	1269	1.0	78	MRS-MRT 110	70	20	623	1.0	79
MRA 100/130	6.3	224	1421	1.2	78	MRS 130	50	28	809	1.4	93
MRA 100/150	5.0	280	1490	1.1	108	MRS 130	35	40	1141	1.0	93
MRA 100/150	3.5	400	2292	1.1	108	MRS 150	29	49	1342	1.1	123
MRA 100/150	3.0	448	2613	1.0	108	MRA 100/130	27	53	1531	1.0	107
<b>2.2 kW</b>							min <sup>-1</sup>	i =	Nm	SF	kg
MRS-MRT 70	280	5	92	1.9	28	MRS 150	25	56	1534	0.9	123
MRS-MRT 70	200	7	92	1.8	28	<b>7.5 kW</b>					
MRS-MRT 70	140	10	129	1.4	28		min <sup>-1</sup>	i =	Nm	SF	kg
MRS-MRT 70	93	15	187	1.0	28	MRS-MRT 110	200	7	315	1.7	88
MRS-MRT 85	70	20	246	1.3	33	MRS-MRT 110	140	10	445	1.2	88
MRS-MRT 85	50	28	319	1.0	33	MRS-MRT 110	93	15	645	0.9	88
MRS-MRT 110	35	40	438	1.6	55	MRS 130	93	15	652	1.5	102
MRS-MRT 110	29	49	522	1.2	55	MRS 130	70	20	860	1.1	102
MRS-MRT 110	25	56	588	1.0	55	MRS 130	50	28	1103	1.0	102
MRS-MRT 110	20	70	704	0.9	55	MRS 150	35	40	1576	1.1	132
MRS 130	18	80	756	1.1	69	MRA 100/130	26	53	1041	1.4	116
MRS 150	14	100	945	1.2	99	MRA 100/150	25	56	1036	1.1	146
MRA 100/130	14	98	985	1.5	83	<b>11 kW</b>					
MRA 100/130	12	125	1369	1.3	83		min <sup>-1</sup>	i =	Nm	SF	kg
MRA 100/130	10	140	1324	1.0	83	MRS 150	200	7	467	2.3	148
MRA 100/130	8.9	160	1729	1.0	83	MRS 150	140	10	660	1.9	148
MRA 100/150	7.0	200	1861	1.1	113	MRS 150	93	15	968	1.5	148
MRA 100/150	6.3	230	2175	1.2	113	MRS 150	70	20	1261	1.1	148
<b>3.0 kW</b>							min <sup>-1</sup>	i =	Nm	SF	kg
MRS-MRT 70	280	5	91	1.9	30	MRS 150	50	28	1660	0.9	148
MRS-MRT 70	200	7	126	1.3	30	<b>15 kW</b>					
MRS-MRT 70	140	10	176	1.0	30		min <sup>-1</sup>	i =	Nm	SF	kg
MRS-MRT 85	93	15	255	1.1	35	MRS 150	200	7	637	1.7	158
MRS-MRT 85	70	20	336	1.0	35	MRS 150	140	10	900	1.4	158
MRS-MRT 110	50	28	435	1.5	57	MRS 150	93	15	1320	1.1	158
MRS-MRT 110	35	40	598	1.2	57						
MRS-MRT 110	29	49	712	0.9	57						
MRS 130	29	49	722	1.3	71						
MRS 130	25	56	814	1.2	71						
MRS 150	20	70	974	1.3	101						
MRA 100/130	20	70	1074	1.3	85						
MRS 150	18	80	1064	1.1	101						
MRA 100/130	18	80	1277	1.0	85						
MRS 150	14	100	1289	0.9	101						
MRA 100/130	14	98	1344	1.1	85						
MRA 100/130	12	120	1793	1.0	85						
MRA 100/150	10	140	1891	1.1	101						
MRA 100/150	8.9	160	2357	1.1	101						
<b>4.0 kW</b>											
	min <sup>-1</sup>	i =	Nm	SF	kg						
MRS-MRT 85	280	5	122	2.3	43						
MRS-MRT 85	200	7	168	1.5	43						
MRS-MRT 85	140	10	235	1.1	43						
MRS-MRT 110	93	15	344	1.6	65						
MRS-MRT 110	70	20	453	1.4	65						
MRS-MRT 110	50	28	581	1.1	65						
MRS 130	35	40	829	1.4	79						
MRS 130	29	49	963	1.0	79						
MRS 130	25	56	1085	0.9	79						

## Gearboxes Series RS & RT

Electric motors

Dimensions

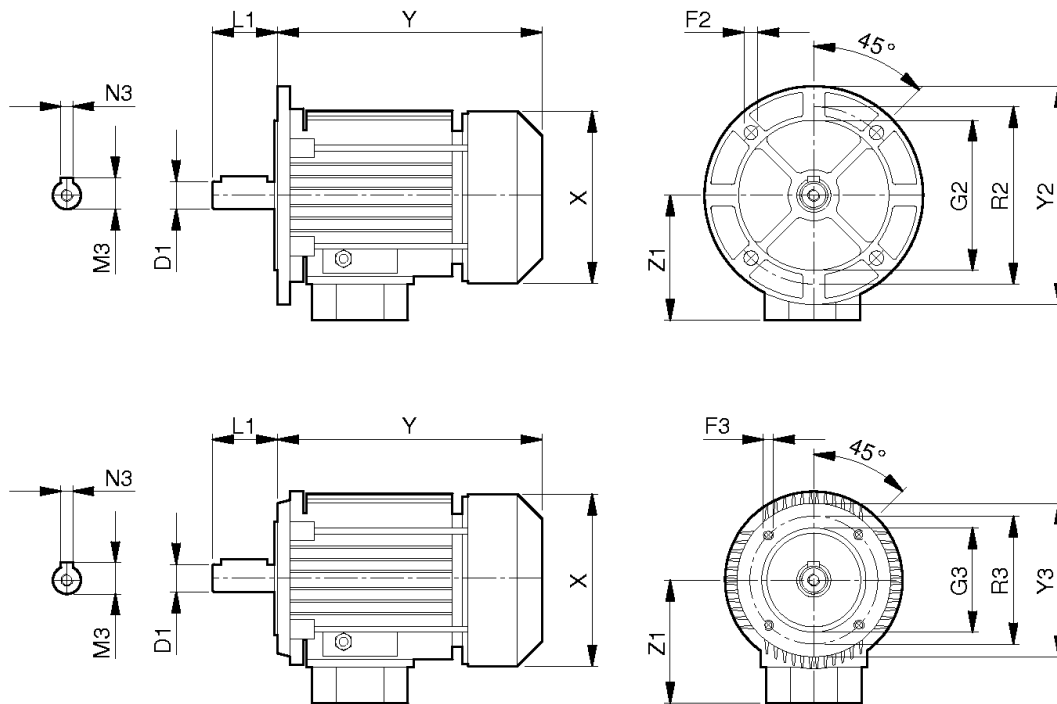

MOTOR IEC	56	63	71	80	90 S / L	100 / 112	132 S / M	160 M / L
$D_1(j_6) \times L_1$	9 x 20	11 x 23	14 x 30	19 x 40	24 x 50	28 x 60	38 x 80	42 x 110
$F_2$	7	9	9	11	11	14	14	18
$F_3$	M.5	M.5	M.6	M.6	M.8	M.8	M.10	12
$G_2(j_6)$	80	95	110	130	130	180	230	250
$G_3(j_6)$	50	60	70	80	95	110	130	180
$M_3$	10.4	12.8	16.3	21.8	27.3	31.3	41.3	45.3
$N_3$	3	4	5	6	8	8	8	8
$R_2$	100	115	130	165	165	215	265	300
$R_3$	65	75	85	100	115	130	165	215
$X$	110	123	140	159	176	195 / 219	258	315
$Y$	168	185	215	238	255 / 280	309 / 328	368 / 405	478 / 522
$Y_2$	120	140	160	200	200	250	300	350
$Y_3$	80	90	105	120	140	160	200	250
$Z_1$	108	110	121	138	149	160 / 172	192	220
Weight kg	2,5	4,5	6,0	10,0	13,5	21 / 29	43 / 52	68 / 78

Not binding dimensions

# Gearboxes Series RS & RT

## Dimensions

## Single worm gear boxes RS

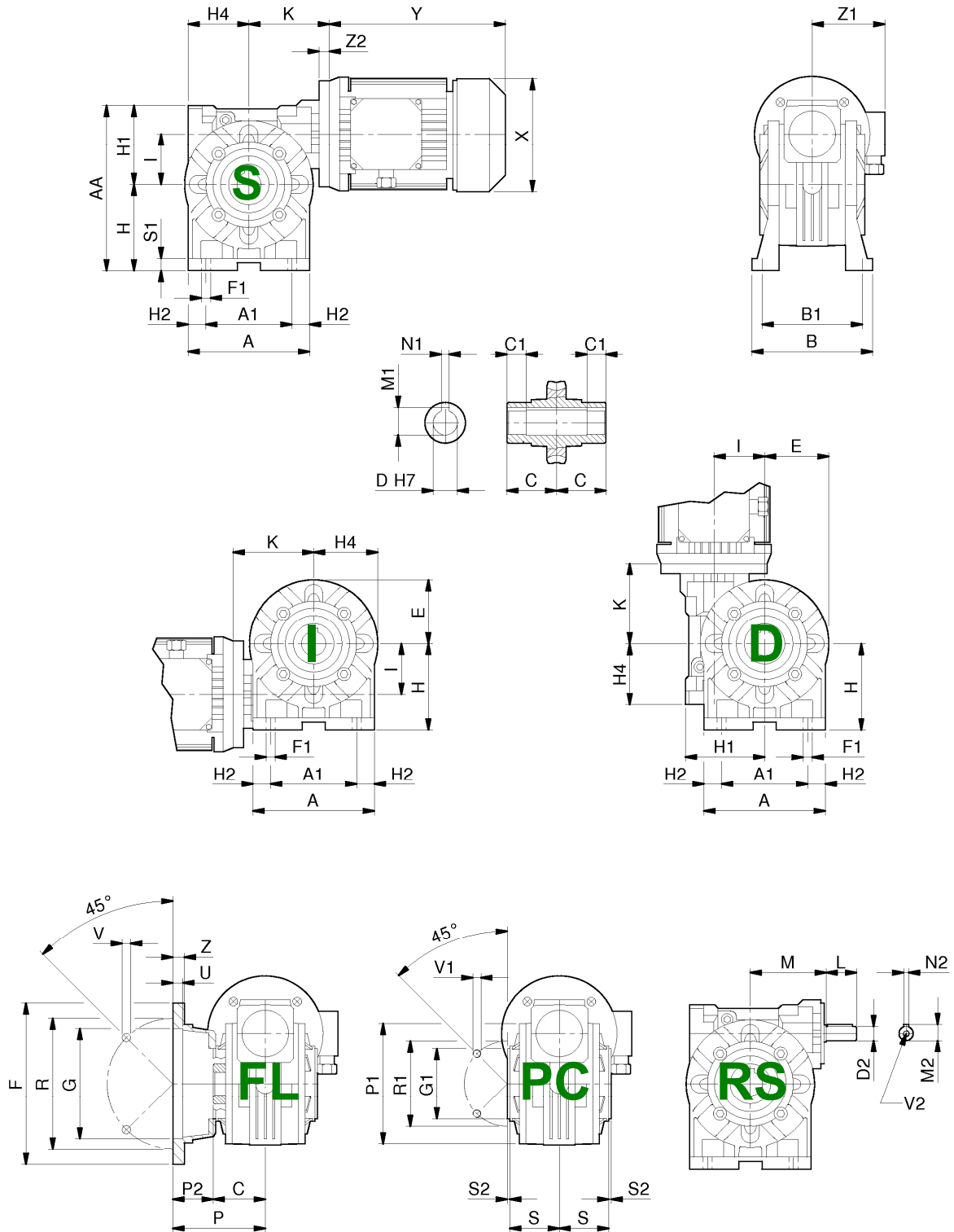



## Gearboxes Series RS & RT

### Single worm gear boxes RS

### Dimensions

RS	28	40	50	60	70	85	110	130	150
A <sub>1</sub>	52	70	85	95	120	140	200	235	260
AA	99	138	163	192	221	252	342	400	454
B	78	102	119	136	#	168	200	230	250
B <sub>1</sub>	66	84	99	111	116	140	162	190	210
C	30	41	49	60	60	61	77,5	90	105
C <sub>1</sub>	26.5	26	30.5	39	37.5	38.5	52.5	85	100
D <sub>(H7)</sub>	14	19	24	25	28	32	42	48	55
D* <sub>(H7)</sub>	---	18	25	---	30	35	---	---	---
D <sub>2 (H6)</sub>	9	11	14	19	19	24	28	38	42
E	34	50	61	70	80	98	125	143	168
F	70	140	160	180	200	200	250	300	350
F <sub>1</sub>	5,5	7	9	11	11	13	14	15	19
G <sub>(H8)</sub>	40	95	110	115	130	130	180	230	250
G <sub>1 (F8)</sub>	42	60	70	70	80	110	130	180	180
H	52	71	85	100	115	135	172	200	230
H <sub>1</sub>	47	67	78	92	106	117	170	200	224
H <sub>2</sub>	9	15	17,5	21,5	19	26,5	25	25,5	38
H <sub>4</sub>	40	50	60	72	86	103	142	159	183
I	28	40	50	60	70	85	110	130	150
K	57.5	70.5	83-88*	93-94*	117-118*	134-137*	151-153*	165-166*	191-211*
L	20	23	30	40	40	40	60	80	100
M	50	65	75	87	110	123,5	146	166	195
M <sub>1</sub>	16,3	21,8	27,3	28,3	31,3	35,3	45,3	51,8	59,3
M <sub>2</sub>	10,2	12,5	16	22,5	22,5	27	31	41	45
N <sub>1</sub>	5	6	8	8	8	10	12	14	16
N <sub>2</sub>	3	4	5	6	6	8	8	10	12
P	49	82	91,5	116	111	100	150	150	160
P <sub>1</sub>	67	94	100	102	118	150	200	234	250
P <sub>2</sub>	19	41	42,5	56	51	39	72,5	60	55
R	56	115	130	150	165	165	215	265	300
R <sub>1</sub>	56	83	85	85	100	130	165	215	215
S	32	38	49	57,5	57	56,5	74,5	87	102
S <sub>1</sub>	6	9	12	12	14	15	17	19	20
S <sub>2</sub>	-3	2	2,5	2,5	3	3	2,5	5	5
U	4	6	10	10	12	6	5	5	6
V	6,5 (4)	9 (4)	9 (4)	11 (4)	13 (4)	13 (4)	15 (8)	15 (8)	19 (8)
V <sub>1</sub>	M6x6 (4)	M6x9 (4)	M8x12 (4)	M8x15 (8)	M8x18 (8)	M10x20 (8)	M12x21 (4)	M12x24 (4)	M14x30 (8)
V <sub>2</sub>	M4x10	M4x10	M6x15	M8x20	M8x20	M8x20	M8x20	M10x22	M12x25
Z	6	10	10	11	14	14	16	18	20

# - 137 - Bolted feet                      - 142 - Integral feet

D\* - Bore on demand

V<sub>1</sub> - 90° for RS28

(\*) - IEC71-B14 (**FRS50**) - IEC71-B14 (**FRS60**) - IEC 80-B14 (**FRS70**) - IEC 90-B14 (**FRS85**)

(\*) - IEC100/112-B14 (**FRS110**) - IEC 100/112-B5 (**FRS130**) - IEC 160-B5 (**FRS150**)

Motor dimensions: see page 33

Not binding dimensions

# Gearboxes Series RS & RT

## Dimensions

## Helical worm gear boxes RA

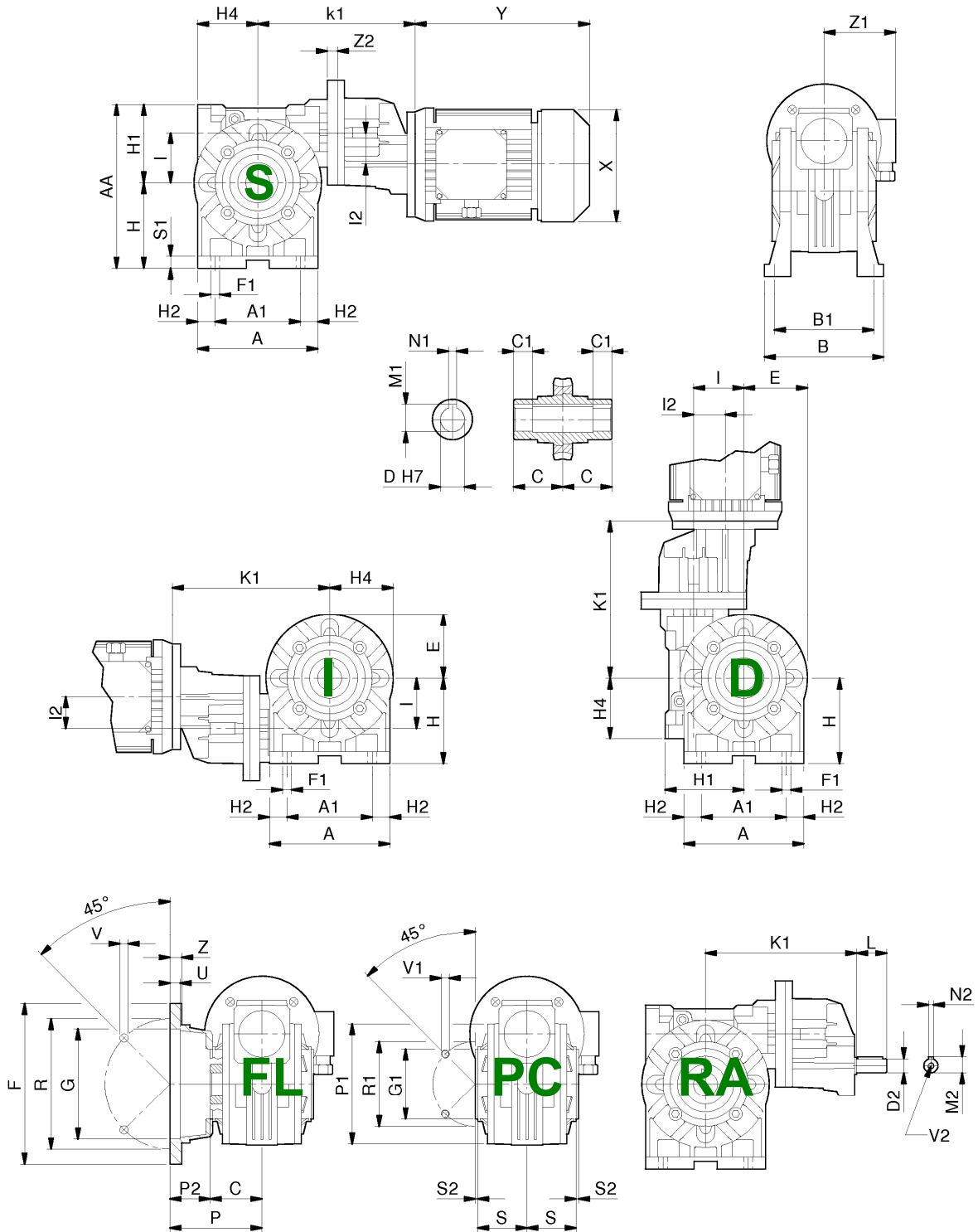

## Gearboxes Series RS & RT

### Helical worm gear boxes RA

### Dimensions

RA	63/40	63/50	63/60	71/50	71/60	71/70	71/85	80/60	80/70	80/85	80/110	100/110	100/130	100/150
A <sub>1</sub>	70	85	95	85	95	120	140	95	120	140	200	250	235	260
AA	138	163	192	163	192	221	252	192	221	252	342	200	400	454
B	102	119	136	119	136	#	168	136	#	168	200	333	230	250
B <sub>1</sub>	84	99	111	99	111	116	140	111	116	140	162	200	190	210
C	41	49	60	49	60	60	61	60	60	61	77,5	162	90	105
C <sub>1</sub>	26	30,5	39	30,5	39	37,5	38,5	39	37,5	38,5	52,5	52,5	85	
D	19	24	25	24	25	28	32	25	28	32	42	77,5	48	55
D*	18	25	---	25	---	30	35	---	30	35	---	42	---	---
D <sub>2</sub>	11	11	11	14	14	14	14	19	19	19	19	---	19	19
E	50	61	70	61	70	80	98	70	80	98	125	24	143	168
F	140	160	180	160	180	200	200	180	200	200	250	125	300	350
F <sub>1</sub>	7	9	11	9	11	11	13	11	11	13	14	250	15	19
G	95	110	115	110	115	130	130	115	130	130	180	14	230	250
G <sub>1</sub>	60	70	70	70	70	80	110	70	80	110	130	180	180	180
H	71	85	100	85	100	115	135	100	115	135	172	130	200	230
H <sub>1</sub>	67	78	92	78	92	106	117	92	106	117	170	172	200	224
H <sub>2</sub>	15	17,5	21,5	17,5	21,5	19	26,5	21,5	19	26,5	25	161	25,5	38
H <sub>4</sub>	50	60	72	60	72	86	103	72	86	103	142	25	159	189
I	40	50	60	50	60	70	85	60	70	85	110	139	130	150
I <sub>1</sub>	32	32	32	40	40	40	40	50	50	50	50	110	75	75
K	153,	171	177	173	183	209	224	207	232,	250,	264,	63	290	316
				178*	188*	214*	229*					328	300*	326*
L	23	23	23	30	30	30	30	40	40	40	40	50	40	40
M <sub>1</sub>	21,8	27,3	28,3	27,3	28,3	31,3	35,3	28,3	31,3	35,3	45,3	45,3	51,8	59,3
M <sub>2</sub>	12,5	12,5	12,5	16	16	16	16	22,5	22,5	22,5	22,5	27	22,5	22,5
N <sub>1</sub>	6	8	8	8	8	8	10	8	8	10	12	12	14	16
N <sub>2</sub>	4	4	4	5	5	5	5	6	6	6	6	8	6	6
P	82	91,5	116	91,5	116	111	100	116	111	100	150	150	150	160
P <sub>1</sub>	94	100	102	100	102	118	150	102	118	150	200	200	234	250
P <sub>2</sub>	41	42,5	56	42,5	56	51	39	56	51	39	72,5	72,5	60	55
R	115	130	150	130	150	165	165	150	165	165	215	215	265	300
R <sub>1</sub>	83	85	85	85	85	100	130	85	100	130	165	165	215	215
S	38	49	57,5	49	57,5	57	56,5	57,5	57	56,5	74,5	74,5	87	102
S <sub>1</sub>	9	12	12	12	12	14	15	12	14	15	17	17	19	20
S <sub>2</sub>	2	2,5	2,5	2,5	2,5	3	3	2,5	3	3	2,5	2,5	5	5
U	6	10	10	10	10	12	6	10	12	6	5	5	5	6
V	9 (4)	9 (4)	11 (4)	9 (4)	11 (4)	13 (4)	13 (4)	11 (4)	13 (4)	13 (4)	15 (8)	15 (8)	15 (8)	19 (8)
V <sub>1</sub>	M6x9 (4)	M8x12 (4)	M8x15 (8)	M8x12 (4)	M8x15 (8)	M8x18 (8)	M10x2 (8)	M8x15 (8)	M8x18 (8)	M10x2 (8)	M12x2 (8)	M12x2 (8)	M12x2 (8)	M14x3 (8)
V <sub>2</sub>	M4x10	M4x10	M4x10	M6x15	M6x15	M6x15	M6x15	M8x20	M8x20	M8x20	M8x20	M8x20	M8x20	M8x20
Y <sub>1</sub>	105	105	105	120	120	120	120	140	140	140	140	140	200	200
Z	10	10	11	10	11	14	14	11	14	14	16	16	18	20

# - 137 - Bolted feet                      - 142 - Integral feet  
D\* - Bore on demand  
V<sub>1</sub> - 90° for RS28  
(\*) - IEC71-B14 (FRA 71/....) - IEC100-B5 ( FRA130 ) - IEC100-B5 ( FRA150 )  
Motors dimensions : see page 33  
Not binding dimensions

# Gearboxes Series RS & RT

## Dimensions

## Two stage worm gear boxes RS/RS

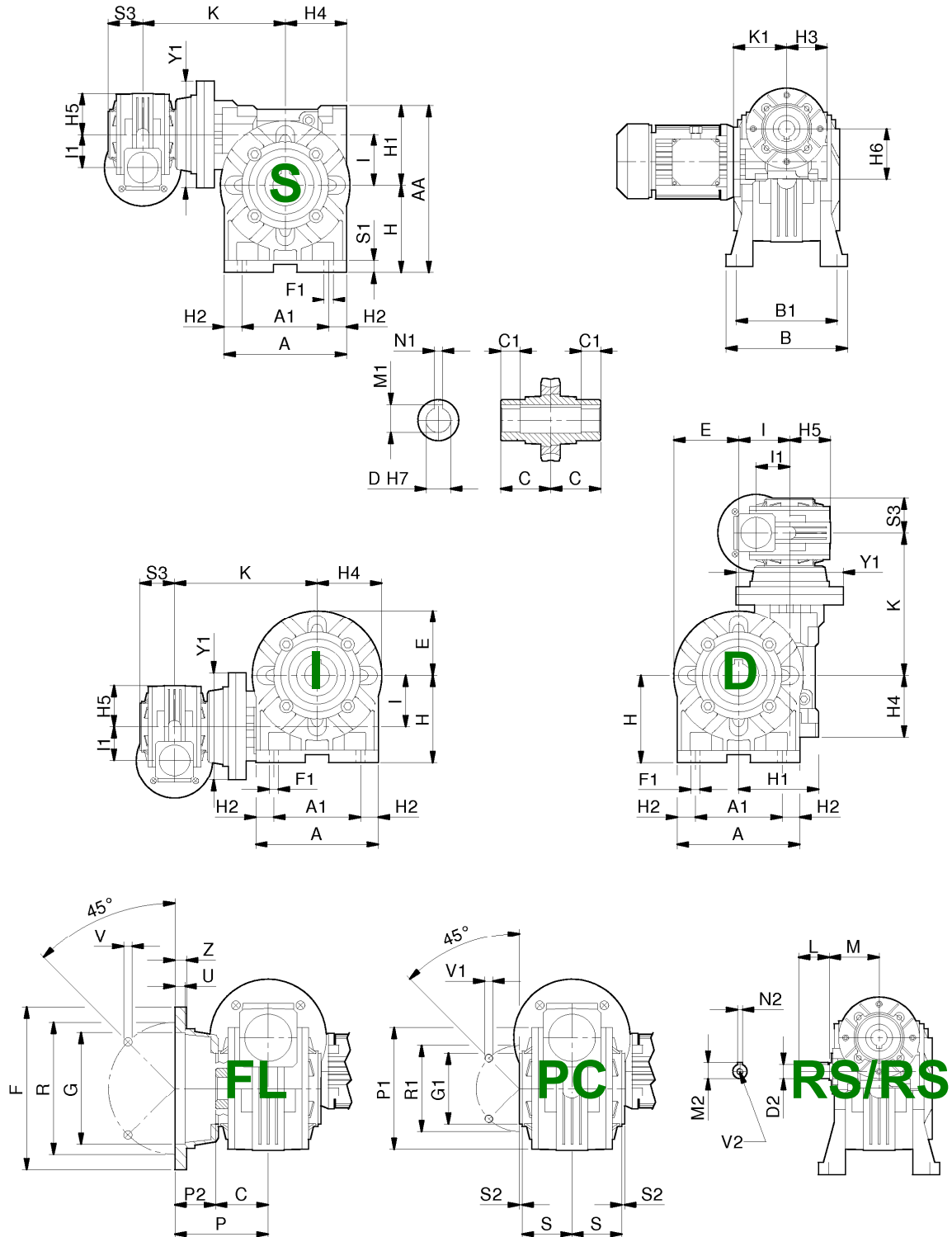



# Gearboxes Series RS & RT

Dimensions

Alternative mountings RS

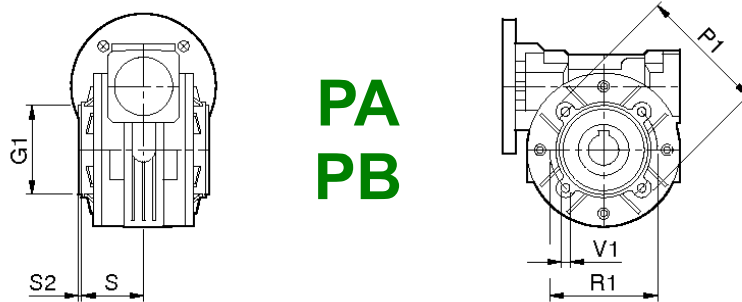
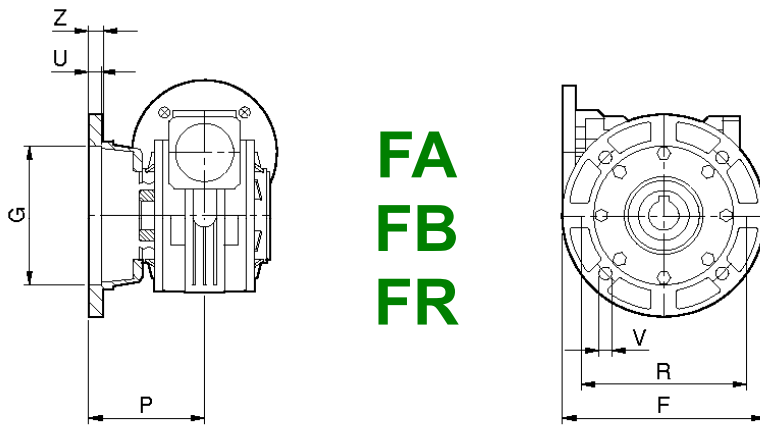
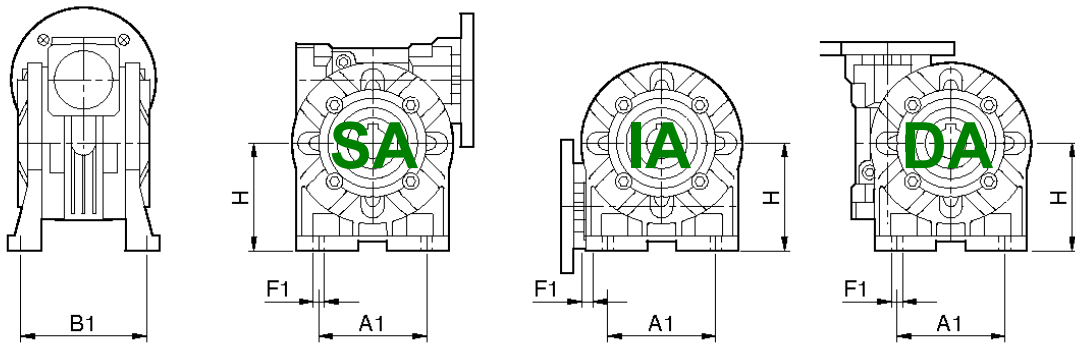

## Gearboxes Series RS & RT

### Alternative mountings RS

### Dimensions

RS	28	40	50	60	70	85	110	130	150
<b>SA - IA - DA</b>									
A <sub>1</sub>	---	52	63	---	---	140	---	---	---
B <sub>1</sub>	---	81	98.5	---	---	146	---	---	---
F <sub>1</sub>	---	8.5	9	---	---	11	---	---	---
H	---	72	82	---	---	142	---	---	---

<b>FA</b>									
F	80	114	125	165	165	---	---	---	---
G <sub>(H8)</sub>	50	60	70	110	115	---	---	---	---
P	50.5	69	93	90	116	---	---	---	---
R	68	87	90	130	150	---	---	---	---
U	3.5	5	5	10	4.5	---	---	---	---
V	6.5 (4)	9 (4)	11 (4)	10.5 (4)	11 (4)	---	---	---	---
Z	7	8	10	15	10	---	---	---	---

<b>FB</b>									
F	---	120	---	180	---	210	270	---	---
G <sub>(H8)</sub>	---	80	---	115	---	152	170	---	---
P	---	62	---	86	---	119.5	131.5	---	---
R	---	100	---	150	---	176	230	---	---
U	---	4	---	3.5	---	5	5	---	---
V	---	9 (4)	---	11 (4)	---	11 (4)	13 (4)	---	---
Z	---	9	---	12	---	14	18	---	---

<b>FR</b>									
F	---	---	---	---	160	---	---	---	---
G <sub>(H8)</sub>	---	---	---	---	110	---	---	---	---
P	---	---	---	---	84.5	---	---	---	---
R	---	---	---	---	130	---	---	---	---
U	---	---	---	---	4.5	---	---	---	---
V	---	---	---	---	11 (4)	---	---	---	---
Z	---	---	---	---	14	---	---	---	---

<b>PA</b>									
G <sub>1 (H8)</sub>	---	50	68	75	90	---	---	---	---
P <sub>1</sub>	---	95	110	104	125	---	---	---	---
R <sub>1</sub>	---	65	94	90	110	---	---	---	---
S	---	38	49	47.5	55	---	---	---	---
S <sub>2</sub>	---	2	2.5	5.5	3	---	---	---	---
V <sub>1</sub>	---	M6x8 (4)	M6x12.5(4)	M8x14 (4)	M8x14 (4)	---	---	---	---

<b>PB</b>									
G <sub>1 (H8)</sub>	---	---	60	---	70	---	---	---	---
P <sub>1</sub>	---	---	110	---	116	---	---	---	---
R <sub>1</sub>	---	---	75	---	85	---	---	---	---
S	---	---	49	---	67	---	---	---	---
S <sub>2</sub>	---	---	2.5	---	4	---	---	---	---
V <sub>1</sub>	---	---	M6x12.5(4)	---	M8x14 (4)	---	---	---	---

Not binding dimensions

# Gearboxes Series RS & RT

## Dimensions

## Accessories RS

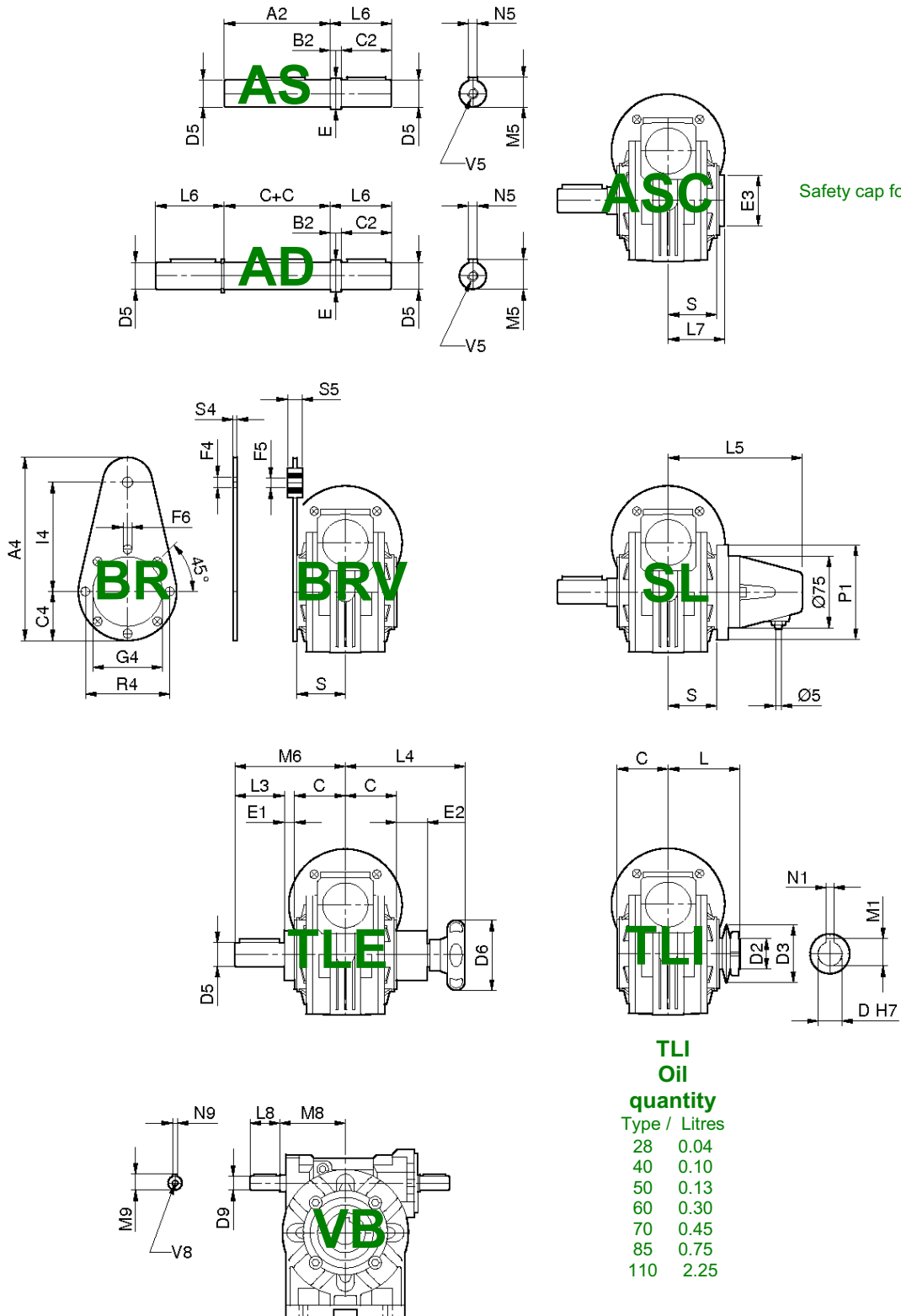



## Gearboxes Series RS & RT

### Accessories RS

### Dimensions

RS		28	40	50	60	70	85	110	130	150
<b>AS &amp; AD</b>	A <sub>2</sub>	58	80	95	117	117	119	153	177	207
	B <sub>2</sub>	1	10	10	10	10	10	10	20	20
	C	30	41	49	60	60	61	77.5	90	105
	C <sub>2</sub>	30	40	45	50	60	70	100	110	110
	D <sub>5</sub> (g6)	14	19 (18)	24 (25)	25	28	32 (35)	42	48	55
	E	14	22	28	30	34	38	50	58	63
	L <sub>6</sub>	31	50	55	60	70	80	106	130	130
	M <sub>5</sub>	16	21.5	27	28	31	35	45	51.5	59
	N <sub>5</sub>	5	6	8	8	8	10	12	14	16
	V <sub>5</sub>	M5x10	M8x20	M8x20	M8x20	M8x20	M10x25	M10x25	---	---

<b>ASC</b>	E <sub>3</sub>	42	55	62	62	72	90	120	---	---
	L <sub>7</sub>	36	48.5	55.5	68.5	67	77	85	---	---
	S	27.5	38.5	46.5	57	57	67	74	---	---

<b>BR BRV</b>	A <sub>4</sub>	138	168	185	235	295	313	388	---	---
	C <sub>4</sub>	38	43	60	55	65	75	100	---	---
	F <sub>4</sub>	10.5	10.5	10.5	10.5	10.5	20.5	20.5	---	---
	F <sub>5</sub>	10	10	10	10	10	20	20	---	---
	F <sub>6</sub>	7	7	9	9	9	12	13	---	---
	G <sub>4</sub>	55	60	70	80	95	110	130	---	---
	I <sub>4</sub>	80	90	100	150	150	200	250	---	---
	R <sub>4</sub>	65	75	85	95	115	130	165	---	---
	S <sub>4</sub>	4	4	4	6	6	6	6	---	---
	S <sub>5</sub>	15	15	15	20	20	25	25	---	---

<b>SL</b>	L <sub>5</sub>	100	110	120	130	130	140	155	---	---
	P <sub>1</sub>	77	88	100	110	132	160	200	---	---
	S	27.5	38.5	46.5	57	57	67	74	---	---

<b>TLE</b>	D <sub>6</sub>	52	70	70	70	80	100	100	---	---
	E <sub>1</sub>	10	12	12	15	14	19	24	---	---
	E <sub>2</sub>	28	37	31	40	46	57	71	---	---
	L <sub>3</sub>	30	40	50	50	60	70	80	---	---
	L <sub>4</sub>	94	116	118	128	146	168	201	---	---
	M <sub>6</sub>	70	93	111	125	134	150	181	---	---

<b>TLI</b>	D (H7)	14	19	24	25	28	32	42	---	---
	D <sub>2</sub>	40	56	71	71	80	90	125	---	---
	D <sub>3</sub>	14.2 x 20	19.5 x 20.5	24.5 x 28	25.5 x 26	28.5 x 22	32.5 x 27	42.5 x 38.5	---	---
	L	45	61.5	77	86.5	89	94	112.5	---	---
	M <sub>1</sub>	15.4*	21.8	27.3	27.3*	31.3	35.3	45.3	---	---
	N <sub>1</sub> (H9)	5	6	8	8	8	10	12	---	---

<b>VB</b>	D <sub>9</sub>	9	11	14	19	19	24	28	---	---
	L <sub>8</sub>	20	23	30	40	40	50	60	---	---
	M <sub>8</sub>	43	55	65	77	84	106.5	145	---	---
	M <sub>9</sub>	10.2	12.5	16	22.5	22.5	27	31	---	---
	N <sub>9</sub>	3	4	5	6	6	8	8	---	---
	V <sub>8</sub>	M4x10	M4x10	M6x15	M8x20	M8x20	M8x20	M8x20	---	---

\* = Undersized key

- D<sub>5</sub> (..) = Diameter on demand

# Gearboxes Series RS & RT

## Dimensions

## Single worm gear boxes RT

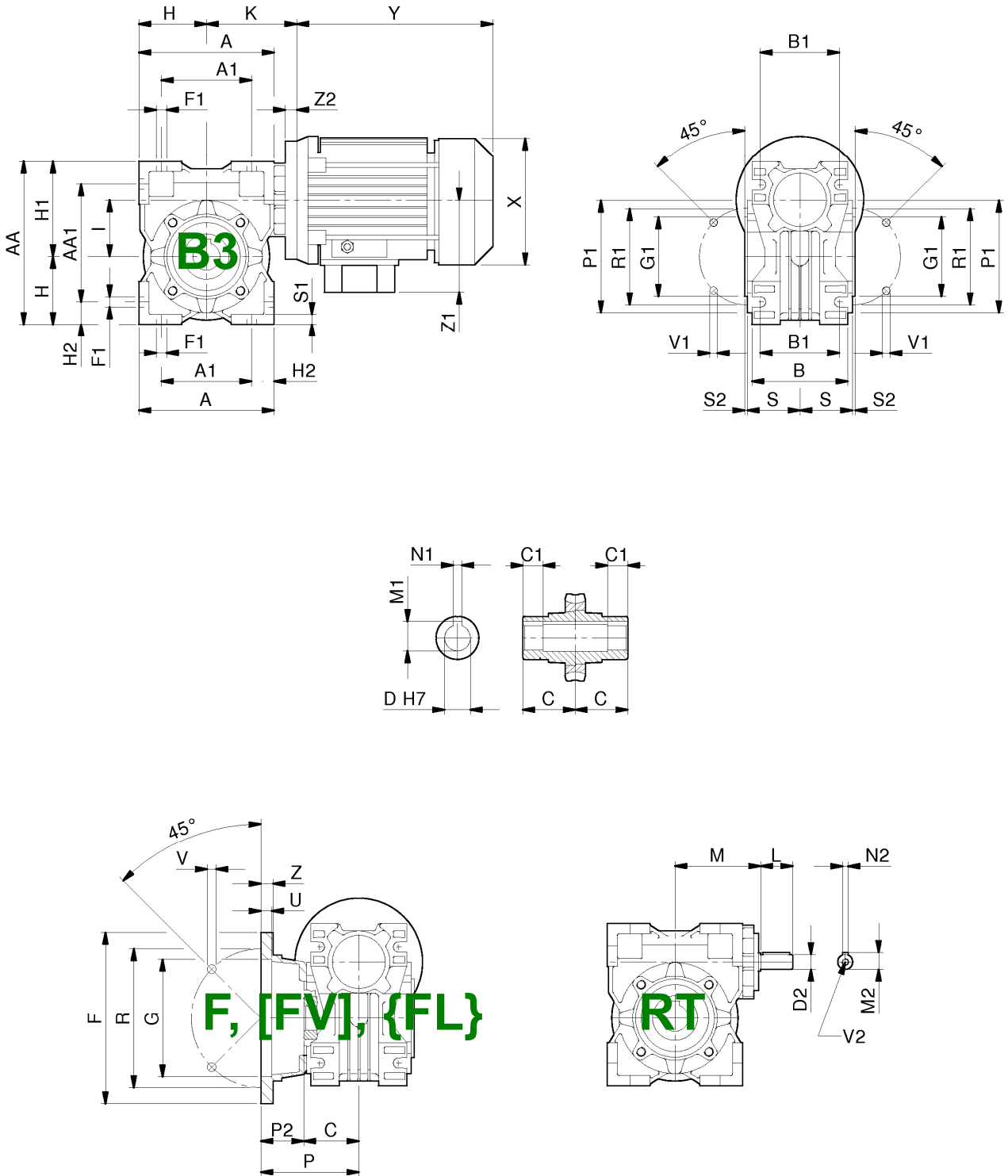

## Gearboxes Series RS & RT

### Single worm gear boxes RT

### Dimensions

RT	28	40	50	60	70	85	110
A	80	100	120	144	172	206	255
A <sub>1</sub>	54	70	80	100	120	140	170
AA	97	121,5	144	174	205	238	295
AA <sub>1</sub>	71	91,5	104	130	153	172	210
B	53	71	85	100	112	130	144
B <sub>1</sub>	44	60	70	85	90	100	115
C	14	41	49	60	60	61	77,5
C <sub>1</sub>	26,5	26	30,5	39	37,5	38,5	52,5
D <sup>(H7)</sup>	14	19	24	25	28	32	42
D* <sup>(H7)</sup>	---	18	25	---	30	35	---
D <sub>2</sub> <sup>(h6)</sup>	9	11	14	19	19	24	28
F	80	110 {110}	125 [160] 125}	180 {180}	200	210	270
F <sub>1</sub>	7	7	9	9	11	13	15
G <sup>(H8)</sup>	50	60 {60}	70 [110] {70}	115 {115}	130	152	170
G <sub>1</sub> <sup>(h8)</sup>	55	60	70	80	95	110	130
H	40	50	60	72	86	103	127,5
H <sub>1</sub>	57	71,5	84	102	119	135	167,5
H <sub>2</sub>	13	15	20	22	26	33	42,5
I	28	40	50	60	70	85	110
K	57,5	70,5	83-88*	93-94*	117-118*	134-137*	151-153*
L	20	23	30	40	40	50	60
M	50	65	75	87	110	123,5	146
M <sub>1</sub>	16,3	21,8	27,3	28,3	31,3	35,3	45,3
M <sub>2</sub>	10,2	12,5	16	22,5	22,5	27	31
N <sub>1</sub>	5	6	8	8	8	10	12
N <sub>2</sub>	3	4	5	6	6	8	8
P	53	69 {99}	93 [90,5] {123}	86 {116}	111	111	131
P <sub>1</sub>	75	86	100	110	130	160	200
P <sub>2</sub>	23	28 {58}	44 [41,5] {74}	25 {56}	51	50	53,5
R	68	87 {87}	90 [130] {90}	150,5 {150,5}	165	175	230
R <sub>1</sub>	65	75	85	95	115	130	165
S	27,5	38,5	46,5	57	57	67	74
S <sub>1</sub>	6	7	8	10	11	14	13
S <sub>2</sub>	2,5	2,5	3	3	3	3	3,5
U	10	4 {4}	5 [11] {5}	6,5 {6,5}	12	6	5
V	7	9 {9}	10,5 [9] {9}	11 {11}	13	13	14
V <sub>1</sub>	M6x10 (4)	M6x8,5 (4)	M8x10 (4)	M8x16 (8)	M8x16 (8)	M10x18 (8)	M10x21 (8)
V <sub>2</sub>	M4x10	M4x10	M6x15	M8x20	M8x20	M8x20	M8x20
Z	7	6 {8}	10 [13] {10}	10 {10}	14	16	18
Z <sub>2</sub>	13	13	13 - 18,5	14 - 15	15,5 - 17,5	15,5 - 18,5	18-20

D\* - Bore on demand

V<sub>1</sub> - 90° for RT28

(\*) - IEC71-B14 (**FRS50**) - IEC71-B14 (**FRS60**) - IEC 80-B14 (**FRS70**) - IEC 90-B14 (**FRS85**) - IEC100/112-B14 (**FRS110**)

Motor dimensions: see page 33

Not binding dimensions

# Gearboxes Series RS & RT

## Dimensions

## Helical worm gear boxes TA

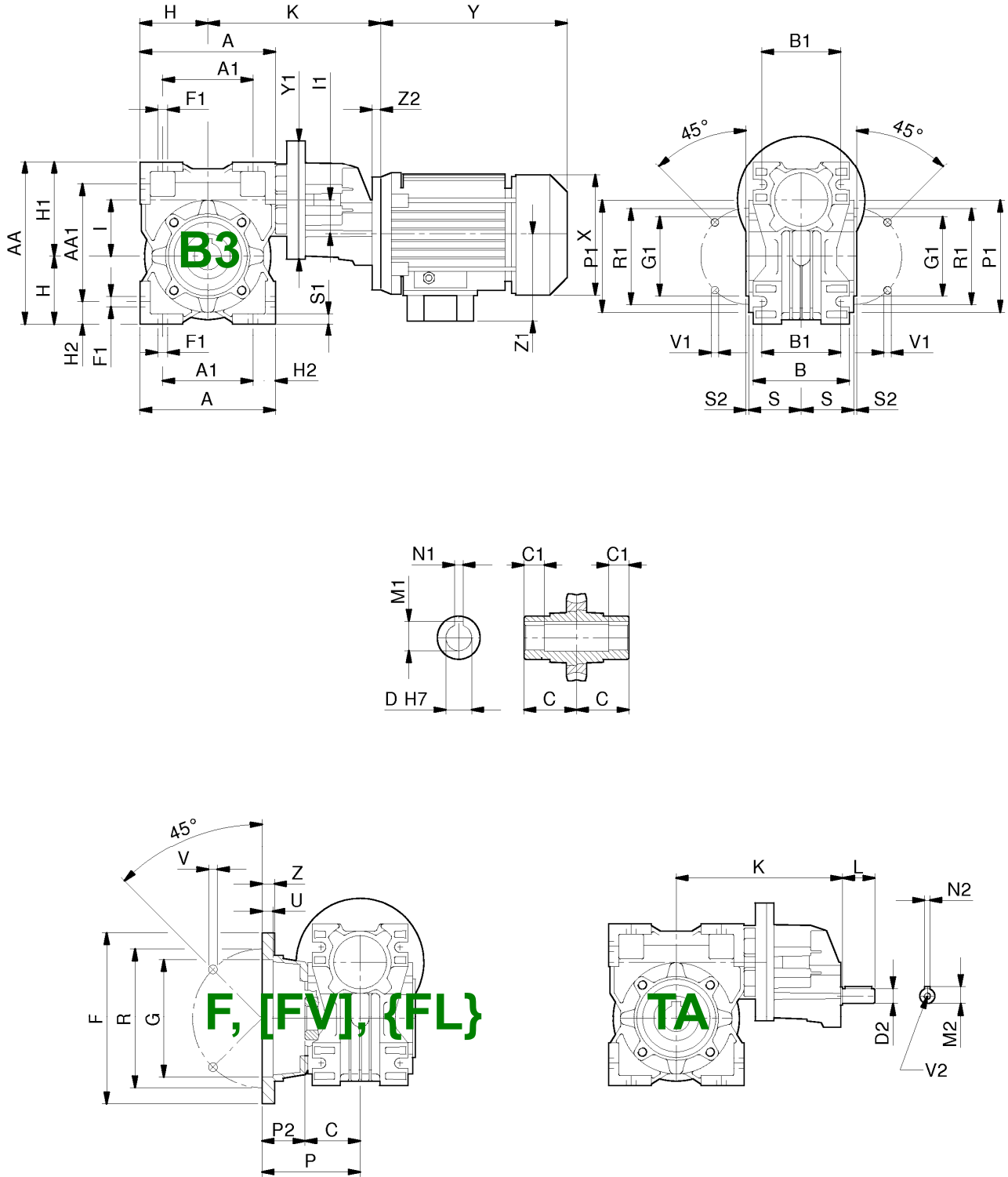

## Gearboxes Series RS & RT

### Helical worm gear boxes TA

### Dimensions

TA	63/40	63/50	63/60	71/50	71/60	71/70	71/85	80/60	80/70	80/85	80/110	100/110
A	100	120	144	120	144	172	206	144	172	206	255	255
A <sub>1</sub>	70	80	100	80	100	120	140	100	120	140	170	170
AA	121,5	144	174	144	174	205	238	174	205	238	295	295
AA <sub>1</sub>	91,5	104	130	104	130	153	172	130	153	172	210	210
B	71	85	100	85	100	112	130	100	112	130	144	144
B <sub>1</sub>	60	70	85	70	85	90	100	85	90	100	115	115
C	41	49	60	49	60	60	61	60	60	61	77,5	77,5
C <sub>1</sub>	26	30,5	39	30,5	39	37,5	38,5	39	37,5	38,5	52,5	52,5
D <sup>(H7)</sup>	19	24	25	24	25	28	32	25	28	32	42	42
D*	18	25	---	25	---	30	35	---	30	35	---	---
D <sub>4</sub>	11	11	11	14	14	14	14	19	19	19	19	24
F	110	125	180	125	180	200	210	180	200	210	270	270
F <sub>1</sub>	7	9	9	9	9	11	13	9	11	13	15	15
G <sup>(H8)</sup>	60 {60}	70 [110]	115	70 [110]	115	130	152	115	130	152	170	170
G <sub>1</sub>	60	70	80	70	80	95	110	80	95	110	130	130
H	50	60	72	60	72	86	103	72	86	103	127,5	127,5
H <sub>1</sub>	71,5	84	102	84	102	119	135	102	119	135	167,5	167,5
H <sub>2</sub>	15	20	22	20	22	26	33	22	26	33	42,5	42,5
I	40	50	60	50	60	70	85	60	70	85	110	110
I <sub>1</sub>	32	32	32	40	40	40	40	50	50	50	50	50
K	153,5	171	177	173-	183	209-	224	207	232,5	250,5	264,5	328
L	23	23	23	30	30	30	30	40	40	40	40	50
M <sub>1</sub>	21,8	27,3	28,3	27,3	28,3	31,3	35,3	28,3	31,3	35,3	45,3	45,3
M <sub>2</sub>	12,5	12,5	12,5	16	16	16	16	22,5	22,5	22,5	22,5	27
N <sub>1</sub>	6	8	8	8	8	8	10	8	8	10	12	12
N <sub>4</sub>	4	4	4	5	5	5	5	6	6	6	6	8
P	69 {99}	93	86 {116}	93	86 {116}	111	111	86 {116}	111	111	131	131
P <sub>1</sub>	86	100	110	100	110	130	160	110	130	160	200	200
P <sub>2</sub>	28 {58}	44	25 {56}	44	25 {56}	51	50	25 {56}	51	50	53,5	53,5
R	87	90	150,5	90 [130]	150,5	165	175	150,5	165	175	230	230
R <sub>1</sub>	75	85	95	85	95	115	130	95	115	130	165	165
S	38,5	46,5	57	46,5	57	57	67	57	57	67	74	74
S <sub>1</sub>	7	8	10	8	10	11	14	10	11	14	13	13
S <sub>2</sub>	2,5	3	3	3	3	3	3	3	3	3	3,5	3,5
U	4 {4}	5 [11] {5}	6,5 {6,5}	5 [11] {5}	6,5 {6,5}	12	6	6,5 {6,5}	12	6	5	5
V	9 {9}	10,5 [9]	11	10,5 [9]	11	13	13	11	13	13	14	14
V <sub>1</sub>	M6x8 (4)	M8x10 (4)	M8x16 (8)	M8x10 (4)	M8x16 (8)	M8x16 (8)	M10x18	M8x16 (8)	M8x16 (8)	M10x18 (8)	M10x21 (8)	M10x21 (8)
V <sub>3</sub>	M4 x 10	M4 x 10	M4 x 10	M6 x 15	M6 x 15	M6 x 15	M6 x 15	M8 x 20	M8 x 20	M8 x 20	M8 x 20	M8 x 20
Y <sub>1</sub>	105	105	105	120	120	120	120	140	140	140	140	140
Z	6 {8}	10 [13] {10}	10 {10}	10 [13] {10}	10 {10}	14	16	10 {10}	14	16	18	18
Z <sub>2</sub>	13	13	13	13 - 18,5	13 - 18,5	13 - 18,5	13 - 18,5	14 - 15	14 - 15	14 - 15	14 - 15	14 - 15

D\* - Bore on demand

V<sub>1</sub> - 90° for RT28

(\*) - IEC71-B14 (FTA 71/....)

Motor dimensions: see page 33

Not binding dimensions

# Gearboxes Series RS & RT

## Dimensions

## Two stage worm gear boxes RT/RT

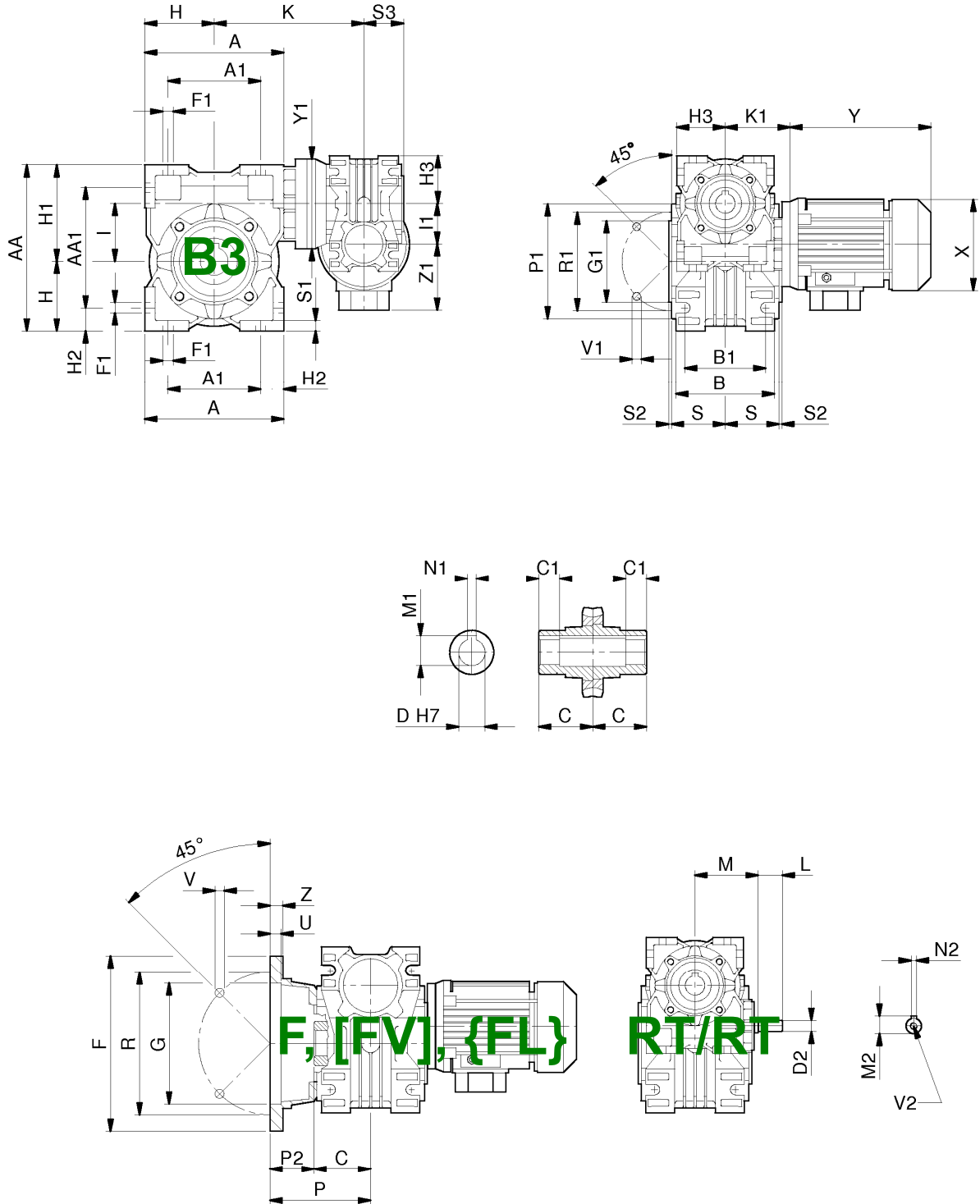

## Gearboxes Series RS & RT

### Two stage worm gear boxes RT/RT

### Dimensions

RT/RT	28/28	28/40	28/50	28/60	40/70	40/85	50/110
A	80	100	120	144	172	206	255
A <sub>1</sub>	54	70	80	100	120	140	170
AA	97	121,5	144	174	205	238	295
AA <sub>1</sub>	71	91,5	104	130	153	172	210
B	53	71	85	100	112	130	144
B <sub>1</sub>	44	60	70	85	90	100	115
C	30	41	49	60	60	61	77,5
C <sub>1</sub>	26,5	26	30,5	39	37,5	38,5	52,5
D (H7)	14	19	24	25	28	32	42
D* (H7)	---	18	25	---	30	35	---
D <sub>2</sub> (h6)	9	9	9	9	11	11	14
F	80	110 {110}	125 [160] {125}	180 {180}	200	210	270
F <sub>1</sub>	7	7	9	9	11	13	15
G (H8)	50	60 {60}	70 [110] {70}	115 {115}	130	152	170
G <sub>1</sub> (h8)	55	60	70	80	95	110	130
H	40	50	60	72	86	103	127,5
H <sub>1</sub>	57	71,5	84	102	119	135	167,5
H <sub>2</sub>	13	15	20	22	26	33	42,5
H <sub>3</sub>	40	40	40	40	50	50	60
I	28	40	50	60	70	85	110
I <sub>1</sub>	28	28	28	28	40	40	50
K	79,5	118,5	129	145,5	143,5	199	203
K <sub>1</sub>	57,5	57,5	57,5	57,5	70,5	70,5	83 - 88*
L	20	20	20	20	23	23	30
M	50	50	50	50	65	65	75
M <sub>1</sub>	16,3	21,8	27,3	28,3	31,3	35,3	45,3
M <sub>2</sub>	10,2	10,2	10,2	10,2	12,5	12,5	16
N <sub>1</sub>	5	6	8	8	8	10	12
N <sub>2</sub>	3	3	3	3	4	4	5
P	53	69 {99}	93 [90,5] {123}	86 {116}	111	111	131
P <sub>1</sub>	75	86	100	110	130	160	200
P <sub>2</sub>	23	28 {58}	44 [41,5] {74}	25 {56}	51	50	53,5
R	68	87 {87}	90 [130] {90}	150,5 {150,5}	165	175	230
R <sub>1</sub>	65	75	85	95	115	130	165
S	27,5	38,5	46,5	57	57	67	74
S <sub>1</sub>	6	7	8	10	11	14	13
S <sub>2</sub>	2,5	2,5	3	3	3	3	3,5
S <sub>3</sub>	30	30	30	30	41	41	49
U	10	4 {4}	5 [11] {5}	6,5 {6,5}	12	6	5
V	7	9 {9}	10,5 [9] {9}	11 {11}	13	13	14
V <sub>1</sub>	M6x10 (4)	M6x8,5 (4)	M8x10 (4)	M8x16 (8)	M8x16 (8)	M10x18 (8)	M10x21 (8)
V <sub>2</sub>	M4x10	M4x10	M4x10	M4x10	M4x10	M4x10	M6x15
Y <sub>1</sub>	80	90	90	90	120	120	120
Z	7	6 {8}	10 [13] {10}	10 {10}	14	16	18

D\* - Bore on demand

V1 - 90° for RT28

(\*) - IEC71-B14 (FRS50)

Motor dimensions: see page 33

Not binding dimensions

# Gearboxes Series RS & RT

## Dimensions

## Accessories RT

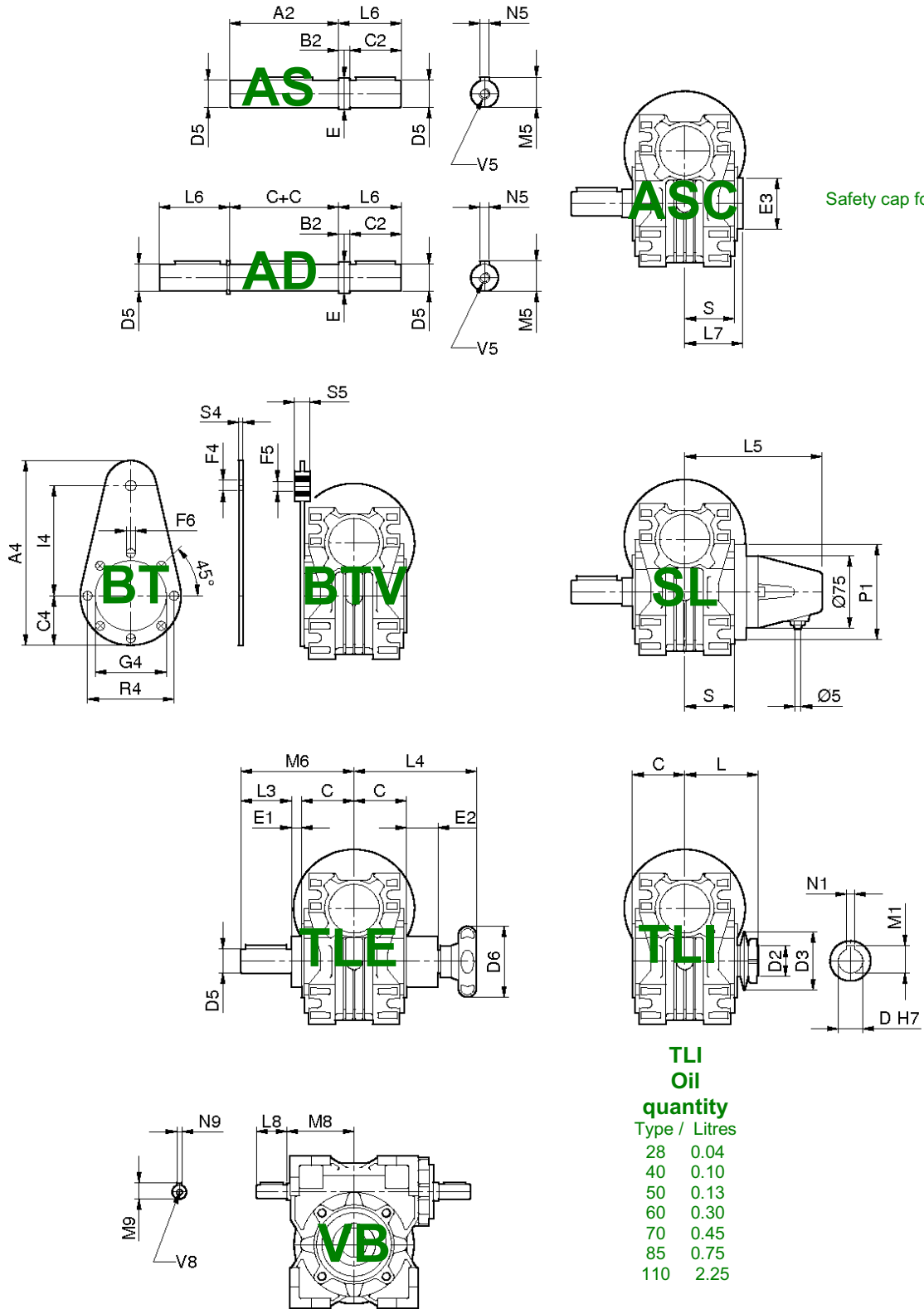



## Gearboxes Series RS & RT

### Accessories RT

### Dimensions

RT	28	40	50	60	70	85	110
<b>AS &amp; AD</b> A <sub>2</sub>	58	80	95	117	117	119	153
B <sub>2</sub>	1	10	10	10	10	10	10
C	30	41	49	60	60	61	77.5
C <sub>2</sub>	30	40	45	50	60	70	100
D <sub>5</sub> (g6)	14	19 (18)	24 (25)	25	28	32 (35)	42
E	14	22	28	30	34	38	50
L <sub>6</sub>	31	50	55	60	70	80	110
M <sub>5</sub>	16	21.5	27	28	31	35	45
N <sub>5</sub>	5	6	8	8	8	10	12
V <sub>5</sub>	M5x10	M8x20	M8x20	M8x20	M8x20	M10x25	M10x25
<b>ASC</b> E <sub>3</sub>	50	52	62	75	90	100	120
L <sub>7</sub>	36	48.5	55.5	68.5	67	77	85
S	27.5	38.5	46.5	57	57	67	74
<b>BT &amp; BTV</b> A <sub>4</sub>	138	168	185	235	295	313	388
C <sub>4</sub>	38	43	60	55	65	75	100
F <sub>4</sub>	10.5	10.5	10.5	10.5	10.5	20.5	20.5
F <sub>5</sub>	10	10	10	10	10	20	20
F <sub>6</sub>	7	7	9	9	9	12	13
G <sub>4</sub>	55	60	70	80	95	110	130
I <sub>4</sub>	80	90	100	150	150	200	250
R <sub>4</sub>	65	75	85	95	115	130	165
S <sub>4</sub>	4	4	4	6	6	6	6
S <sub>5</sub>	15	15	15	20	20	25	25
<b>SL</b> L <sub>5</sub>	96	113	123	133	133	139	150
P <sub>1</sub>	78	90	100	110	130	160	200
S	27.5	38.5	46.5	57	57	67	74
<b>TLE</b> D <sub>6</sub>	52	70	70	70	80	100	100
E <sub>1</sub>	10	12	12	15	14	19	24
E <sub>2</sub>	28	37	31	40	46	57	71
L <sub>3</sub>	30	40	50	50	60	70	80
L <sub>4</sub>	94	116	118	128	146	168	201
M <sub>6</sub>	70	93	111	125	134	150	181
<b>TLI</b> D (H7)	14	19	24	25	28	32	42
D <sub>2</sub>	40	56	71	71	80	90	125
D <sub>3</sub>	14.2 x 20	19.5 x 20.5	24.5 x 28	25.5 x 26	28.5 x 22	32.5 x 27	42.5 x 38.5
L	45	61.5	77	86.5	89	94	109
M <sub>1</sub>	15.4*	21.8	27.3	27.3*	31.3	35.3	45.3
N <sub>1</sub> (H9)	5	6	8	8	8	10	12
<b>VB</b> D <sub>9</sub>	9	11	14	19	19	24	28
L <sub>8</sub>	20	23	30	40	40	50	60
M <sub>8</sub>	43	55	65	77	84	106.5	145
M <sub>9</sub>	10.2	12.5	16	22.5	22.5	27	31
N <sub>9</sub>	3	4	5	6	6	8	8
V <sub>8</sub>	M4x10	M4x10	M6x15	M8x20	M8x20	M8x20	M8x20

D<sub>5</sub> (..) = Diameter on demand

\* = Undersized key

Not binding dimensions

## Gearboxes Series RS & RT

### Dimensions

### One stage helical gear box XA

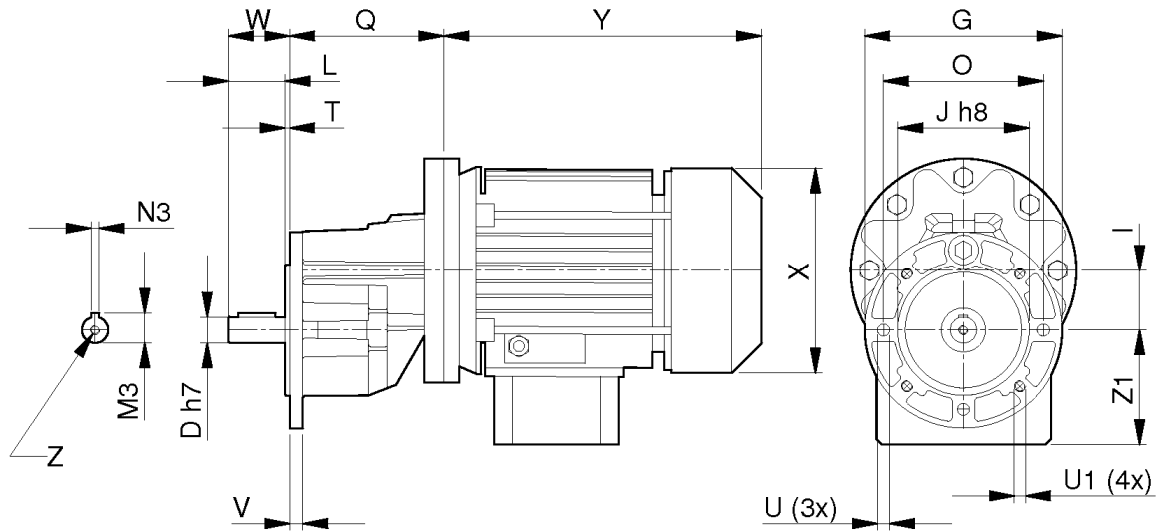

XA	D <sub>H7</sub>	G	I	J <sub>h8</sub>	L	O	Q	U	U1	T	V	W	Z
63	14	105	32	70	30	85	83	6.5	M6	2.5	7	32.5	M5x10
71	19	120	40	80	40	100	90	5.5	M6	2.5	7.5	42.5	M8x20
80	24	140	50	95	49.5	115	114	9	M8	2.5	10.5	52	M8x20
100	28	200	63	130	57.5	165	177	10.5	10.5	2.5	12	60	M10 x 22

IEC	56	63	71	80	90 S / L	100	112
H	108	110	121	138	149	160	160
X	168	185	215	238	255 / 280	309	309
Y	110	123	140	159	176	195	195

## Gearboxes Series RS & RT

### Back-Driving and Self-Locking

When back-driving a worm gear set using the worm wheel as input, the efficiency is lower than forward-driving and, by varying the design data, back-drive efficiency can be reduced to zero obtaining a self-locking, or irreversible, gear set.

When back-driving the worm gear, internal friction tends to lock the mesh, and the bigger the applied torque is, the more mesh friction increases proportionally augmenting the lockage at the same time.

The most obvious example is during braking or slowing-down where the inertial load will try to back-drive the worm shaft.

A worm gear is intended as a self-locking unit when the lead angle is less than the friction angle (arc tangent of friction coefficient).

Tooth contact is dynamic even when the mesh velocity is zero, as vibrations in a non-rotating gear set can induce motion in the tooth contact.

To provide a safety factor, a 3° lead angle is recommended for full self-locking condition, and 10° lead angle for poor self-locking condition, according to the table of relations between lead angles and self-locking.

Lead angle	Static self-locking
$\beta > 20^\circ$	Full back-driving
$10^\circ < \beta < 20^\circ$	High back-driving
$5^\circ < \beta < 10^\circ$	Good back-driving Poor self-locking
$3^\circ < \beta < 5^\circ$	Poor back-driving Good self-locking
$1^\circ < \beta < 3^\circ$	Full self-locking

## Gearboxes Series RS & RT

### Gearing data

	i =	5	7	10	15	20	28	40	49	56	70	80	100
<b>RS/RT 28</b>	$m_x$		1.50	1.40	1.40	1.10	1.50	1.10	0.90	0.75	0.60	0.55	0.45
	$\beta$	---	23°11'	16°41'	11°18'	10°23'	6°06'	5°14'	4°19'	3°03'	2°27'	2°37'	2°20'
	$z_1$		4	3	2	2	1	1	1	1	1	1	1
<b>RS/RT 40</b>	$m_x$	2,00	2.10	2.00	2.00	1.50	2.10	1.50	1.25	1.10	0.90	0.80	0.65
	$\beta$	30°57'	21°36'	16°41'	11°18'	8°31'	5°39'	4°17'	3°48'	3°25'	3°01'	2°51'	2°38'
	$z_1$	6	4	3	2	2	1	1	1	1	1	1	1
<b>RS/RT 50</b>	$m_x$	2,50	2.70	2.50	2.50	1.90	2.70	1.90	1.60	1.40	1.10	1.00	0.80
	$\beta$	30°57'	23°52'	16°41'	11°18'	5°59'	6°19'	4°31'	4°14'	3°42'	2°44'	2°51'	2°17'
	$z_1$	6	4	3	2	2	1	1	1	1	1	1	1
<b>RS/RT 60</b>	$m_x$	3,15	3.30	3.10	3.10	2.40	3.30	2.40	2.00	1.70	1.40	1.20	1.00
	$\beta$	36°32'	25°33'	19°0'	12°55'	11°18'	6°49'	5°42'	5°11'	3°55'	3°38'	2°51'	2°51'
	$z_1$	6	4	3	2	2	1	1	1	1	1	1	1
<b>RS/RT 70</b>	$m_x$	3,60	3.90	3.60	3.60	2.80	3.90	2.80	2.30	2.00	1.60	1.40	1.15
	$\beta$	34°01'	26°51'	18°38'	12°40'	11°18'	7°12'	5°42'	4°48'	4°05'	3°16'	2°51'	2°38'
	$z_1$	6	4	3	2	2	1	1	1	1	1	1	1
<b>RS/RT 85</b>	$m_x$	4,40	4.70	4.40	4.40	3.40	4.70	3.40	2.80	2.50	2.00	1.74	1.40
	$\beta$	34°47'	26°05'	19°09'	13°02'	11°18'	6°58'	5°52'	4°52'	4°45'	3°48'	3°14'	2°40'
	$z_1$	6	4	3	2	2	1	1	1	1	1	1	1
<b>RS/RT 110</b>	$m_x$		6.10	5.80	5.80	4.40	6.10	4.40	3.60	3.20	2.60	2.30	1.80
	$\beta$	---	26°22'	20°43'	14°09'	11°18'	7°04'	5°42'	4°43'	4°29'	3°54'	3°39'	2°34'
	$z_1$		4	3	2	2	1	1	1	1	1	1	1
<b>RS 130</b>	$m_x$		7.25	6.90	6.85	5.35	7.25	5.30	4.35	4.00	3.15	2.70	2.25
	$\beta$	---	26°57'	21°20'	14°06'	13°5'	7°14'	6°18'	5°18'	6°20'	4°33'	3°30'	3°40'
	$z_1$		4	3	2	2	1	1	1	1	1	1	1
<b>RS 150</b>	$m_x$		8.25	8.00	8.15	6.20	8.45	6.25	5.10	4.60	3.60	3.15	2.60
	$\beta$	---	25°33'	21°48'	16°22'	13°24'	7°35'	7°07'	5°48'	6°11'	4°17'	3°45'	3°43'
	$z_1$		4	3	2	2	1	1	1	1	1	1	1

$m_x$  = Axial module  
 $z_1$  = Number of starts  
 $\beta$  = Lead angle (rh)  
 $20^\circ$  = Pressure angle

# Gearboxes Series RS & RT

## Direction of Rotation

### WORMSHAFT UPWARDS

- RS - RT

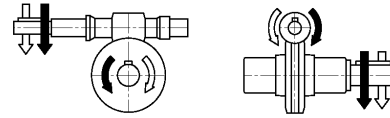

- RA - TA

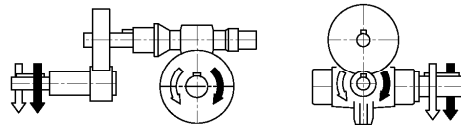

- RS/RS
- RT/RT

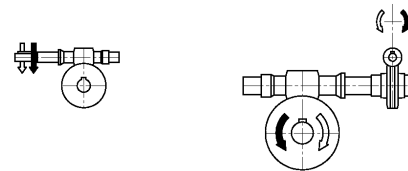

### WORMSHAFT DOWN-WARDS

- RS - RT

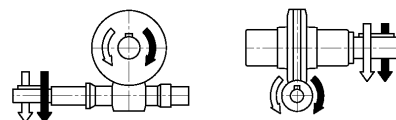

- RA - TA

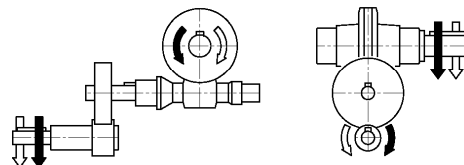

- RS/RS
- RT/RT



## Gearboxes Series RS & RT

### **Abstract of OPERATION AND MAINTENANCE INSTRUCTIONS**

(complete manual on [www.varvel.com](http://www.varvel.com))

Variable speed and reduction gearboxes are not part of the field of application of the Machinery Directive, art.1(2), and they must not be put into service until the machinery into which they are to be incorporated, has been declared in conformity with the provision of art. 4(2), annex II(B) of Machinery Directives 98/37/CEE/22.6.98 and for Italy only, of DL 459/24.7.96.

#### **Installation**

Check if the unit to be installed, is properly selected to perform the required function and that its mounting position complies with the order.

The nameplate reports such information.

Check mounting stability to ensure the unit runs without vibrations or overloads.

#### **Running**

The unit may be connected for clockwise or counter-clockwise rotation.

The unit must be stopped as soon as defective running or unexpected noise occur, remove the faulty part or return the unit to the factory for checking.

If the faulty part is not replaced, other parts can also be affected, causing more severe damage and making the identification of initial cause more difficult.

#### **Maintenance**

Although the units are no-load run tested in the factory before despatch, it is recommended not to run them at maximum load for the first 20-30 running hours to allow the proper running in.

The gearboxes are delivered already filled with long-life synthetic oil and, in case of replacement or topping, do not mix with mineral lubricants.

#### **Handling**

When hoisting, use relevant housing locations or eyebolts if provided, or foot or flange holes.

Never hoist on any moving part.

#### **Painting**

Carefully protect oil seals, coupling faces and shafts when units are re-painted.

#### **Long-term storage**

For storage longer than three months, apply anti-oxidants onto shafts and machined surfaces, and protective grease on oil seal lips.

#### **Product's Environmental Management**

In conformity with Environmental Certification ISO 14001, we recommend the following to dispose of our products:

- scraped components of the units to be delivered to authorized centres for metal object collection;
- oils and lubricants drained from the units to be delivered to Exhausted Oil Unions;
- packages (pallets, carton boxes, paper, plastic, etc.) to lead into regeneration/recycling circuits as far as possible, by delivering separate waste classes to authorized companies.



## *A socially responsible company*

*To the scope of intensifying our commitment to society, Varvel since 2004 started an ongoing support programme with three non-profit institutions: UNICEF (United Nations Children's Fund), MSF (Médecins sans Frontières) and ANT (National Cancer Association). Environmental respect and protection are also part of Varvel's values and this is why Varvel certified in 2001 its Environmental System to standard UNI EN ISO 14001.*

---



**RN/RO/RV**



**RS/RT**



**RD**



**RG**



**RP**



**VR/VS**



**VARVEL®**  
MOTION CONTROL SINCE 1955

**Varvel SpA**

Via 2 Agosto 1980, 9  
40056 Crespellano (BO) Italy

☎ +39 051 6721811

☎ +39 051 6721825

[varvel@varvel.com](mailto:varvel@varvel.com)

[www.varvel.com](http://www.varvel.com)